

THE 7 MYTHS OF POLYURETHANE FINISHES

We Test the  
Incredible  
Brese Plane

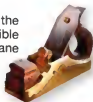

# POPULAR WOODWORKING

Learn How. Discover Why. Build Better.

AUGUST 2008 #170

## Built-to-Last Bookshelves

Master the Tricky  
Through-Tenon

6 Greene & Greene  
Masterworks:  
An Insider's Tour

5 Shop Tricks for  
Blue Painter's Tape

Understand  
Federal Furniture



popularwoodworking.com





46



57



66

## 38 Craftsman Bookcase

This Craftsman-style bookcase incorporates authentic details such as wedged through-tenons – plus it has a secret drawer.

BY ROBERT W. LANG

## 46 Folding Campaign Table

This butler's tray-on-stand is typical of 18th-century knock-down furniture for the military campaign trail, with durable joints, simple design and ingenious hardware mechanisms.

BY MARIO RODRIGUEZ

## 51 Thickness Planers

WOODWORKING ESSENTIALS

Though planers seem simple and safe, there are some serious operational and safety issues to consider. Follow these rules and your work will be better – and you won't get hurt.

BY MARC ADAMS

## 57 Federal Furniture

How beautiful veneer, superb inlay and simple carving on Federal furniture became this author's *raison d'être* in woodworking.

BY ROB MILLARD

## 62 Multiple Through Mortise-and-Tenon Joints

This joint adds an interesting design feature to any casework, and this technique makes the joint far easier to execute than you might think.

BY ROB PORCARO

## 66 Greene & Greene Masterworks

A century ago, two sets of brothers conceived a design movement that combined Arts & Crafts and Asian aesthetics – an enduring style instantly recognizable today.

BY DAVID MATHIAS  
& ROBERT W. LANG



51

Number 170, August 2008. Popular Woodworking ISSN 0894-8823 USPS 752-250 is published 6 times a year in February, April, June, August, October, November and December by P-W Publications, Inc. Editorial and advertising offices are located at 4700 E. Galbraith Road, Cincinnati, Ohio 45236; tel. 513-531-3222. Unsolicited manuscripts, photographs and artwork should include a return postage on a self-addressed, stamped envelope (SASE) otherwise they will not be returned. Subscription rates: A year's subscription (7 issues) is \$19.95 (outside of the U.S. add \$7/year) • Canada Publications Mail Agreement No. 40023316. Canadian return address: 2833 Kew Drive, Windsor, ON N8B 1B7 • Copyright 2008 by Popular Woodworking. Periodicals postage paid at Cincinnati, Ohio, and at additional mailing offices. Postmaster: Send all address changes to Popular Woodworking, P.O. Box 400236, Palm Coast, FL 32142-0236. Canada GST Reg. #R12304716 • Printed and imported in the U.S.A.



22



26



76

- 10** A Shout Out  
for The Wood  
Whisperer  
OUT ON A LIMB  
BY CHRISTOPHER SCHWARZ
- 12** Router Plane:  
Best Hand Tool  
for Sizing Tenons  
LETTERS  
FROM OUR READERS

- 16** A Back-saving  
Vise Extension  
TRICKS OF THE TRADE  
FROM OUR READERS
- 22** 18th-century  
Chairmaking II  
ARTS & MYSTERIES  
BY ADAM CHERUBINI
- 26** The Magic of  
Masking Tape  
THE WOOD WHISPERER  
BY MARC SPAGNUOLO

- 36** Wayne Anderson  
Smoother  
ENDURANCE TEST  
BY CHRISTOPHER SCHWARZ
- 76** The 7 Myths of  
Polyurethane  
FLEXNER ON FINISHING  
BY BOB FLEXNER
- 80** Memories and  
Milestones  
OUT OF THE WOODWORK  
BY DAVID MATHIAS

ON THE  
AUGUST  
COVER

The arresting grain of the sapele, along with purpleheart wedges, adds visual appeal to Senior Editor Robert W. Lang's Craftsman-style bookcase. Page 38.

COVER PHOTO BY AL PARRISH

4 ■ Popular Woodworking August 2008



- 28** Contemporary  
Bookshelves  
I CAN DO THAT  
BY MEGAN FITZPATRICK
- 30** 24" Omnijig  
Joinery System  
TOOL TEST  
BY OUR STAFF



I Can  
Do  
That

28

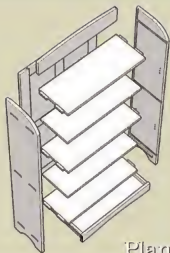

Plans



Video



Slide Show

## Project Plans

### Craftsman Bookcase

You'll find project plans and a complete cut list for Senior Editor Robert W. Lang's Craftsman Bookcase in the article (page 38), but he's also posted a Google SketchUp model so you can take the case apart, and examine individual pieces and assemblies.  
[popularwoodworking.com/aug08](http://popularwoodworking.com/aug08)

## Video Gallery

### Lumber Selection

Senior editors Robert W. Lang and Glen D. Huey took a road trip to Frank Miller Lumber in Indiana where they shot two videos: One on buying hardwoods for any project, and another on the selection process Bob used for the sapele Craftsman Bookcase in this issue.  
[popularwoodworking.com/video](http://popularwoodworking.com/video)

### How to: Fan Inlay

Rob Millard walks you step by step through the process of making a sand-shaded, corner fan inlay. This easy inlay will add a Federal detail to any style project.  
[popularwoodworking.com/video](http://popularwoodworking.com/video)

### Joinery Jigs

For the Craftsman Bookcase, Senior Editor Robert W. Lang had to cut multiple through-mortises and shelf dados. To make the job easier and more accurate, he made a couple jigs – he shares them with you on a video.  
[popularwoodworking.com/video](http://popularwoodworking.com/video)

### Masking Tape Magic

Marc Spagnuolo (a.k.a. The Wood Whisperer) shows you just some of the many uses for masking tape in your shop.  
[popularwoodworking.com/video](http://popularwoodworking.com/video)

## New This Month:

**WOODWORKING**  
 In America   
 Hand Tools & Techniques Conference 2008

Register now for Woodworking In America, a unique hand-tool event (Nov. 14-16 in Berea, Ky.) that brings together the nation's top woodworkers and toolmakers. For more information and to register, visit:  
[WoodworkingInAmerica.com](http://WoodworkingInAmerica.com)

### Planer Safety Tips

For a printable list of planer safety tips to supplement Marc Adams's article on page 51, visit:  
[popularwoodworking.com/aug08](http://popularwoodworking.com/aug08)

### Greene & Greene Slide Show

David Mathias took far more pictures for the Greene & Greene story than we could use in this issue. So, we've posted a downloadable slide show to complement the article.  
[popularwoodworking.com/aug08](http://popularwoodworking.com/aug08)

### And More!

Visit [popularwoodworking.com/aug08](http://popularwoodworking.com/aug08) to find a complete list of all the online resources for this issue – including videos, additional drawings and photos.

## popularwoodworking.com

- Contact Customer Service  
[popularwoodworking.com/customerservice](http://popularwoodworking.com/customerservice)
- Free Project Plans  
[popularwoodworking.com/projectplans](http://popularwoodworking.com/projectplans)
- Article Index  
[popularwoodworking.com/articleindex](http://popularwoodworking.com/articleindex)
- Tool Reviews  
[popularwoodworking.com/toolreviews](http://popularwoodworking.com/toolreviews)
- Magazine Extras  
[popularwoodworking.com/magazineextras](http://popularwoodworking.com/magazineextras)
- Editor Blogs  
[popularwoodworking.com/blogs](http://popularwoodworking.com/blogs)
- Writer's Guidelines  
[popularwoodworking.com/writersguidelines](http://popularwoodworking.com/writersguidelines)
- Contact the Staff  
[popularwoodworking.com/contactus](http://popularwoodworking.com/contactus)

**Mario Rodriguez** has more than 30 years in woodworking as a builder, teacher and writer. After teaching for 17 years in the Restoration Department at the Fashion Institute of New York, Mario now teaches at the Philadelphia Furniture Workshop (philadelphiafurnitureworkshop.com). He's written two books, "Traditional Woodwork" and "Building Fireplace Mantels" (both from Taunton Press), and contributed numerous articles to many woodworking magazines. The Campaign Table (page 46) is Mario's second article for *Popular Woodworking*; the first, on veneering basics, appeared in June 2007 (issue #162).



**Marc Spagnuolo** is the host of the popular web site thewoodwhisperer.com, which offers scads of free instructional woodworking videos, shop tours, audio programs about woodworking and links to other like-minded woodworking sites.

He's also our newest contributor. Marc will be writing a column (which we have cleverly titled "The Wood Whisperer") in every issue on a woodworking technique; this month's is on page 26. In addition to the written word, Marc will be posting a video on our site at [popularwoodworking.com/video](http://popularwoodworking.com/video) that will show that technique in action.



**Adam Cherubini**, contributing editor to *Popular Woodworking* and author of our Arts & Mysteries column, has taken a sabbatical from his engineering design job to pursue furniture making full time. It will come as no surprise to our regular readers that Adam is concentrating his custom furniture business on 18th-century designs, tools and techniques. You can check out his work at [adamcherubini.com](http://adamcherubini.com), and read his blog at [artsandmysteries.com](http://artsandmysteries.com).

Also, Adam has again been selected by *Early American Life* magazine for its prestigious "Directory of Traditional American Crafts," for which each year, a panel of judges (comprised of museum curators, dealers and other experts) reviews submissions and selects only the best. It's an honor bestowed upon only a handful of craftspeople. Our congratulations to Adam on this achievement.

In this issue, Adam concludes his two-part story on building a ladder-back chair, beginning on page 22.

**PUBLISHER & GROUP EDITORIAL DIRECTOR**

Steve Shanesy

**EDITOR** Christopher Schwarz  
x11407 • [chris.schwarz@fwpubs.com](mailto:chris.schwarz@fwpubs.com)

**ART DIRECTOR** Linda Watts  
x11396 • [linda.watts@fwpubs.com](mailto:linda.watts@fwpubs.com)

**SENIOR EDITOR** Robert W. Lang  
x11327 • [robert.lang@fwpubs.com](mailto:robert.lang@fwpubs.com)

**SENIOR EDITOR** Glen D. Huey  
x11293 • [glen.huey@fwpubs.com](mailto:glen.huey@fwpubs.com)

**MANAGING EDITOR** Megan Fitzpatrick  
x11348 • [megan.fitzpatrick@fwpubs.com](mailto:megan.fitzpatrick@fwpubs.com)

**ASSOCIATE EDITOR FOR THE WEB** Drew DePenning  
x11008 • [drew.depenning@fwpubs.com](mailto:drew.depenning@fwpubs.com)

**PHOTOGRAPHER** Al Parrish

**CONTRIBUTING EDITORS**

Adam Cherubini, Bob Flexner, Troy Sexton

F+W PUBLICATIONS, INC.

**CHAIRMAN & CEO** David Nussbaum

**CFO** John Speridakos

**SENIOR VP, MANUFACTURING & PRODUCTION** Phil Graham

**VP, MANUFACTURING** Barbara Ann Schmitz

**EXECUTIVE VP, INTERACTIVE MEDIA** John Lerner

**DIRECTOR, IT** Mike Kuehn

F+W PUBLICATIONS, INC.  
MAGAZINE GROUP

**PRESIDENT** David Blansfield

**VP, CONSUMER MARKETING** Sara DeCarlo

**DIRECTOR, BUSINESS PLANNING** Tom Wandt

**CONFERENCE DIRECTOR** Sara Dumford

**CIRCULATION DIRECTOR** Linda Engel

**NEWSSTAND DIRECTOR** Susan Rose

**DIRECTOR, DIGITAL MEDIA SOLUTIONS** Michael Kushner

**PRODUCTION COORDINATOR** Debbie Thomas

**ADVERTISING**

**ADVERTISING DIRECTOR** Don Schroder

331 N. Arch St., Allentown, PA 18104

TEL 610-821-4425; FAX 610-821-7884

[d.schroder@verizon.net](mailto:d.schroder@verizon.net)

**ONLINE SALES DIRECTOR** Jay Gussak

TEL 212-447-1400 x266

[jay.gussak@fwpubs.com](mailto:jay.gussak@fwpubs.com)

**DISPLAY & CLASSIFIED ADVERTISING**

**SALES COORDINATOR**

Nancy Miller

TEL 513-531-2690 x11228

[nancy.miller@fwpubs.com](mailto:nancy.miller@fwpubs.com)

**SUBSCRIPTION SERVICES:** Subscription inquiries, orders and address changes can be made at [popularwoodworking.com](http://popularwoodworking.com) (click on "Customer Service"). Or by mail: *Popular Woodworking*, P.O. Box 420235, Palm Coast, FL 32142-0235. Or call toll-free 877-860-9140 or 386-246-3369. Include your address with all inquiries. Allow 6 to 8 weeks for delivery.

**NEWSSTAND DISTRIBUTION:** Curtis Circulation Co.,

730 River Road, New Milford, NJ 07646

**ATTENTION RETAILERS:** To carry *Popular Woodworking* in your store, call 800-494-4656 or write Magazine Retail Sales, P.O. Box 5014, Iola, WI 54945-5014.

**BACK ISSUES** are available. Call 800-258-0929

for pricing or visit [popularwoodworking.com](http://popularwoodworking.com).

Send check or money order to: *Popular*

*Woodworking* Back Issues, F+W Publications

Products, 700 E. State St., Iola, WI 54990.

Please specify publication, month and year.



# A Shout-out for The Wood Whisperer

**T**erminology can be a real turn-off. I hope you can remember how daunting it was when you first encountered the weird words of woodworking: rabbit, stuck moulding, resawing and haunched tenon – to name just a few. Once you get familiar with the ideas that these terms represent, the wacky words we use to represent them are incidental.

The Internet has the same language barrier. Few people can really explain the difference between a downstream RSS feed and a post pushed out by Feedburner. But the terms themselves keep a lot of us from enjoying the rich tapestry of woodworking instruction that is offered for free on the web.

So here's my advice: Forget you ever heard the words "blog" or "video podcast" – you don't need to know their meanings to enjoy the instruction that they provide. When you deal with Internet information, all you need to know is that it's much like any other information. It usually comes in three flavors: text, audio and images (until Small-o-Web is invented).

If you've resisted exploring the world wide web of woodworking (the "www"), here's an easy way to start: Visit The Wood Whisperer at [thewoodwhisperer.com](http://thewoodwhisperer.com) and just poke around. Marc Spagnuolo's web site offers a rich array of what you'll find on a high-quality site, and it's fun to read, watch and listen to.

You'll find short videos that are entertaining and informative. You can listen to Marc and his buddy Matt Vanderlist (a

fellow woodworker on the web) chat about the craft and tools in their program called Wood Talk Online. Or you can simply read about projects that Marc or his fans are building, or poke around their shops (a new shop tour is posted every week). And finally, The Wood Whisperer site is a great home base to step out and explore other similar sites.



Need more convincing? Turn to page 26 of this issue and read our first-ever column written by The Wood Whisperer. Every issue, Marc is going to write about a woodworking technique, then he's going to provide a short video for our web site (visit [popularwoodworking.com/video](http://popularwoodworking.com/video) to see it), where you'll also find links to Marc's site and a whole other world of woodworking information.

## And to Prove I'm Serious...

The other important thing to mention here is that we've just hired a new associate editor for the web. His name is Drew DePenning, and he is a maestro of all things digital, from audio to video to web sites. He's going to help expand [popularwoodworking.com](http://popularwoodworking.com) and add more free video, text and audio content to the site as well. So if you haven't checked out our web site lately (or ever) I urge you to stop by. It's completely free. It's rich with information. And it's all there for you – the enthusiastic woodworker. **PW**

## Customer Service

*How can I contact customer service with questions regarding my subscription, including a lost or damaged issue?*  
 Visit [popularwoodworking.com/customer-service](http://popularwoodworking.com/customer-service). Or write to *Popular Woodworking*, P.O. Box 420235, Palm Coast, FL 32142-0235. Or, if you prefer the telephone, call toll-free 877-860-9140 and a customer service representative will be happy to help you.

## *When does my subscription expire?*

The date of your subscription expiration appears on your magazine mailing label, above your name. The date indicates the last issue in your subscription.

## *Can I get back issues of Popular Woodworking?*

Back issues are available while supplies last. Visit [popularwoodworking.com/backissues](http://popularwoodworking.com/backissues). Or if you know the exact month and year of the issue you want, call our customer service department toll-free at 800-258-0929 to order.

## *What if I want more information about the projects and tools I read about in Popular Woodworking?*

For all editorial questions, please write to Popular Woodworking Editorial, 4700 E. Galbraith Road, Cincinnati, OH 45236. Or e-mail [popwood@fwpubs.com](mailto:popwood@fwpubs.com).

## *Does Popular Woodworking offer group discounts?*

Group discounts are available by special arrangement with the publisher. For more details, send an e-mail to [Debbie Paoello](mailto:Debbie.Paoello@fwpubs.com) at [Debbie Paoello](mailto:Debbie.Paoello@fwpubs.com) or call 513-531-2690 x1296.

## *Our Privacy Promise to You*

We make portions of our customer list available to carefully screened companies that offer products and services we believe you may enjoy. If you do not want to receive offers and/or information, please let us know by contacting us at:

List Manager, F+W Publications  
 4700 E. Galbraith Road  
 Cincinnati, OH 45236

## Safety Note

Safety is your responsibility. Manufacturers place safety devices on their equipment for a reason. In many photos you see in *Popular Woodworking*, these have been removed to provide clarity. In some cases we'll use an awkward body position so you can better see what's being demonstrated. Don't copy us. Think about each procedure you're going to perform beforehand.

# Router Plane is the Best Hand Tool For Sizing Tenons to Thickness

I'm a recent newcomer to the craft of woodworking, and due to my limited budget, my accumulation of tools has been slow and methodical. My next major purchase is a rabbeting plane to be used primarily for planing tenons to proper thickness after sawing or splitting them out.

I know you usually give a roundabout answer when asked to recommend specific brands, but I am more interested in what style of plane I should go for. A shoulder plane seems handy, but would the blade be too narrow? Would I be better off with a rabbeting block plane? Or maybe an old wooden rabbit plane of some sort? I'm primarily looking at Lie-Nielsen Toolworks and Lee Valley Tools, but I do love rehabbing old tools if there are vintage Stanley's or woodies that would serve my purpose.

—Justin Tyson, Clayton, Georgia

I would actually recommend a router plane, such as a Stanley No. 71, or a new router plane from Lie-Nielsen or Lee Valley. A router plane is a fantastic tool for sizing tenons to thickness—far more accurate than a rabbet plane (or even a shoulder plane, which is great for shoulders). A router

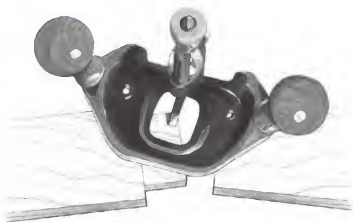

plane can get a set of tenons all to the same thickness—and centered on your stock. You can read about the tool and the technique here: [whifinertools.com/contrib/cSchwarz/z\\_art/routPlanes/rPlane1.asp](http://whifinertools.com/contrib/cSchwarz/z_art/routPlanes/rPlane1.asp)

—Christopher Schwarz, editor

## Shaper-selling Dilemma

I'm wondering if you could help me out of a dilemma. I have a Bridgewood 3-hp shaper and a power feeder that I don't use. I've been offered \$1,000 for it, but I'm not sure if I should sell it. I also have a dedicated router and lift that I was going to build a router table for.

I don't do a lot of furniture making right now but I would like to. If I sell the shaper, will I be wishing I had it in the future?

—Mike Lopez, Saukville, Wisconsin

Shapers are the best tool if you are doing production work. If you plan to create thousands of feet of mouldings, build numerous kitchen cabinet doors or do other types of repetitive processes, a shaper works best.

If your primary interest is building individual pieces and you're not looking at large production runs, your best option is a router and router table.

From a cost basis, shaper cutters are more expensive than router bits. And there are many more profiles available in router bits.

In my experience building bookcases and built-in units for the trade, I found my use of a shaper extensive. However, when I adjusted my woodworking to reproduction furniture and one-off pieces, my router-table usage skyrocketed while my time spent at the shaper all but disappeared. Now, I find the only use I have for my shaper is to make raised panels—and that's simply due to the fact that I have yet to buy a router bit designed for the job.

—Glen D. Huey, senior editor

## A Marker Can Get You In The Sharpening Ballpark

I have long been a fan of editor Christopher Schwarz, and his answer to David Dalrymple about sharpening is obviously correct

(Letters, June 2008, issue #169).

However for the new woodworker, a simple procedure of marking the tool with an ink marker before starting with the first coarse-grit stone then re-marking and changing to the next grit as soon as the ink mark disappears is an easy and effective procedure that eliminates a lot of guesswork. As with all woodworking procedures, repetitive practice makes each operation easier. After 58 years of woodworking I still learn new things from your fine magazine each month.

—Roger Tumbleson, Lake Havasu City, Arizona

Using a marker on your edges is a good way to tip you off that you are sharpening the steel in the right place—it's a great trick and I've used it myself for years.

However, the marker won't show you when you have all the scratches from one grit consist-

CONTINUED ON PAGE 14

ILLUSTRATION BY FAYLES SHAWESY

tently spread across that surface. Or it won't point out when you have a few errant deep scratches left by grinding. Or some loose, coarse abrasive that has sneaked onto your finer stone. (A few deep scratches in a polished edge can reduce your edge life.)

So a marker is a good way to get yourself in the ballpark. Keen eyesight and experience will take you the rest of the way.

—Christopher Schwarz, editor



### Mortise Chisels: The Rationale For Selecting Specific Sizes

Thanks for consistently producing such thorough and valuable tool reviews. I read your various blog entries each week and enjoy the bits of candid humor and honesty in your writing.

I currently do woodworking purely for hobby/relaxation and take a "no electricity" approach by using quality hand tools only. I'm looking at getting my first real mortise chisel(s) and was hoping you could clarify something for me on widths.

Generally, people say to select a mortise chisel equal to the width of the mortise you are cutting, and from your editor's recent tool inventory post on the *Popular Woodworking* blog, you listed owning sizes of  $1/4"$ ,  $3/16"$  and  $1/2"$ . I am interested to know if there's any rhyme or reason behind owning those three sizes?

Based on your glowing review, my current thought is to buy two Ray Iles English Mortise Chisels, one in  $1/2"$  and the other in either  $3/16"$  or  $3/8"$ , because the  $1/4"$  is out of stock. Any thoughts?

—Jesse Flachsbarth, Portland, Oregon

The rule of thumb with hand-cut mortises (and their tenons) is that they should measure one-third of your stock's thickness. So a mortise and a tenon in  $3/4"$ -thick stock should be  $1/4"$ . Hence the  $1/4"$  mortise chisel, which is what I use when I buy  $3/4"$  surfaced stock from the lumberyard.

The  $3/16"$  chisel is for slightly thicker stock, which is more commonly encountered in a hand-tool shop – why thin down those stiles to  $3/4"$  if you don't have to? So the  $3/16"$  chisel is my choice when doing that style of work in stock that I have prepared by hand and purposely left over-thick to save time and effort.

And the  $3/8"$  chisel is for  $1"$ -thick stock, which is a common thickness for tabletops, for example. The  $3/8"$  chisel is just right for mortising the breadboard ends for a tabletop by hand.

You can use these guidelines to pick out the tools you need. If you work with  $1 1/2"$ -thick stock, then a  $1/2"$  chisel is a good idea. Otherwise, it will sit idle.

—Christopher Schwarz, editor

### Beginner Column Doesn't Build Commitment to Woodworking

I am a young woodworker – one of those guys who grew up in his dad's workshop in the garage. During my art degree program, I decided that I wanted woodworking to be my career. I started my shop with a router, an orbital sander, a chop saw and a circular saw, all battery powered and in the storage unit of my apartment. I subscribed to four woodworking magazines and read them like textbooks, cover to cover. It was my goal to learn as many different methods from as many of the greatest woodworkers as possible, so that I could someday simply look at a design and know how to build it.

Five years later, I run my own shop and have read hundreds of publications. I still subscribe to three of my original four publications. The one I don't get anymore reached a point where it failed to challenge me. Its articles started targeting less-than-beginner hobbyists, and stopped showing how great craftsmen did things.

I was dismayed to find two articles in the June 2008 issue of *Popular Woodworking* (#169) on your "I Can Do That" column. These projects are not teaching your readers to have a commitment to studying and perfecting the art you and I love. It is sending the message that anybody can be a woodworker and you don't even have to understand tools

and joinery and how they are used in real furniture work.

Much of my education in woodworking has come from figuring out how to do the amazing projects in *Popular Woodworking* and other publications, with a limited shop. This practice made me build creativity using tools, but it also made learning hand-tool craftsmanship a necessity. Bottom line: If I had to learn woodworking with these articles I would not have been able to accomplish what I have.

*Popular Woodworking* is one of my favorite magazines and I hate to see it become one of those texts that fails to challenge by trying to make woodworking accessible for everyone.

—Jasen Hansen, La Grande, Oregon

### 'I Can Do That' Philosophy Feels Right for One New to the Craft

As a new subscriber to *Popular Woodworking*, I want to say how much I appreciate the "I Can Do That" stories and especially Editor Christopher Schwarz's article "Build Furniture Without a Shop" (June 2008, Issue #169). After doing some simple woodworking, I want to learn more and do more but still stay with a modest set of tools. It just feels like the right path. So, thanks for devoting a section of your magazine to working this way. **PW**

—Rob White, Sandia Park, New Mexico

### Question? Comment? We want to hear from you.

*Popular Woodworking* welcomes comments from readers about the magazine or woodworking in general, as well as questions on all areas of woodworking. We are more than happy to share our woodworking experience with you by answering your questions or adding some clarity to whatever aspect of the craft you are unsure about, and if you have a complaint, we want to address it whenever possible.

Though we receive a good deal of mail, we try to respond to all correspondence in a prompt manner. Published correspondence may be edited for length or style. All correspondence becomes the property of *Popular Woodworking*.

Send your questions and comments via e-mail to [popwood@fwpubs.com](mailto:popwood@fwpubs.com), via fax to 513-891-7196, or by mail to:

Letters  
Popular Woodworking  
4700 E. Galbraith Road  
Cincinnati, OH 45236



THE WINNER:

# A Back-saving Vise Extension

While sawing dovetails for a jewelry box, I found my back was hurting from hunching over my bench vise. In order to work more comfortably, I built this vise extension that works on the same principle as a leg vise. The fixture is nothing more than a couple short sections of 2x12 lumber connected with a veneer-press screw (\$15 from Woodworker's Supply; woodworker.com or 800-645-9292). The longer rear board clamps into my bench vise, while the front board adjusts in and out by turning the veneer-press screw. In use, the workpiece gets clamped between the two boards, projecting from the top at a much

more comfortable working height. The tops of the jaws are chamfered for easier workpiece access and tool maneuverability.

To keep the jaws parallel under clamping pressure, simply insert a shim at the bottom that's the same thickness as your workpiece. To prevent a workpiece from slipping downward when tapping on it with a chisel or other tool, rest the lower end of the workpiece on a tall shim board. The fixture can be made in any size to suit particular types of work, and the clamp can be reused in different-sized vises if desired.

— Hunter Cox, Richmond, Virginia

CONTINUED ON PAGE 18

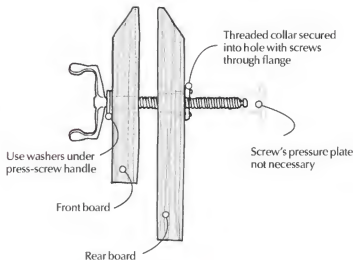
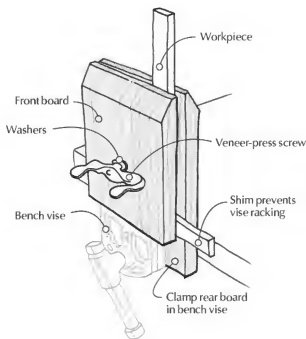

## Cash and prizes for your tricks and tips!

Each issue we publish useful woodworking tips from our readers. Next issue's winner receives a \$250 gift certificate from Lee Valley Tools, good for any item in the catalog or on the web site ([leevalley.com](http://leevalley.com)). (The tools pictured at right are for illustration only, and are not part of the prize.)

Runners-up each receive a check for \$50 to \$100. When submitting a trick (either by mail or e-mail) you must include your complete mailing address and a daytime phone number. If your trick is selected for publication, an editor will need to contact you. All entries become the property of *Popular Woodworking*. You can send your trick by e-mail to [popwoodtricks@fwpubs.com](mailto:popwoodtricks@fwpubs.com), or mail it to Tricks of the Trade, *Popular Woodworking*, 4700 E. Galbraith Road, Cincinnati, OH 45236.



## Quick Rip Fence Adjustment

Like any table saw rip fence, mine needs occasional realignment to the blade. Because my miter gauge slots are aligned parallel to the blade, I just set my fence parallel to the right-hand slot. However, instead of mounting a dial indicator on a miter gauge to check the fence alignment, I made a gauge board that's much quicker to use. The gauge board is nothing more than a piece of straight-sided

scrap plywood attached to a runner that rides in my saw's miter gauge slot. To set the fence, I simply place the runner in the right-hand table slot with the panel extending over to the right. Then I adjust my rip fence so that it contacts the panel's edge when the fence is locked in place.

To ensure that the gauge board is parallel to the table slot, begin by making a runner

that fits your table slot with no side-to-side play. Screw it to the edge of a panel that's a little wider than the distance between your left-hand table slot and the blade. With the runner in the left-hand slot, trim the panel to width. Now it can be used in the right-hand slot with the certainty that it's parallel to the blade.

—Lyndal Anthony, Dubuque, Iowa

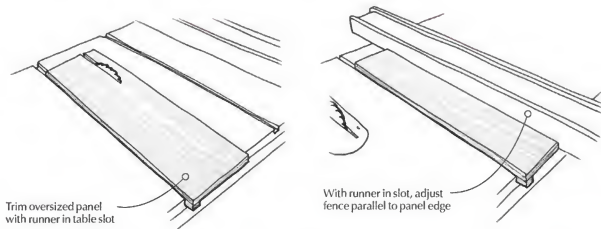

## Creating a Cord Channel for a Lamp Base

I recently ran into a turning dilemma when my wife asked me to make her a quick, inexpensive lamp base. I decided that a two-piece base would do the trick, attaching a long, narrow "neck" to a short, wide base for good footing. Shaping the pieces on the lathe would be easy. The challenge was creating a hole through the axis of the neck to house the lamp cord. The piece was more than twice as long as my longest drill bit and I didn't want to buy a special bit for a one-time use.

To do the job, I ripped the squared turning blank in half on my band saw, lightly jointed the sawn surfaces, then ran a shallow groove

down the inside center of each half. I glued the two halves back together and temporarily attached scrap wood "end caps" with heavy-duty double-stick tape. The caps provided a surface for my lathe centers to bite into. (You could add screws for extra security if you like.) When the turning was complete, I pried off the caps and finished the project. Because of the band saw's narrow kerf, the glue line was virtually invisible. I saved some money and earned some points with the wife at the same time.

—Greg Strately,

Truth or Consequences, New Mexico

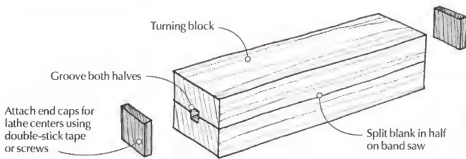

## A Hot Tip for Leveling Throat Plates

Like many woodworkers, I make my own zero-clearance throat plates for the table saw. Instead of installing set screws to level a plate to the table, I simply make the insert a bit thin, then shim it up as necessary. I used to use tape and other material for shims, but I've developed a quicker way.

I simply apply a bead of hot-melt glue to the bottom of the throat plate, then press it into place with a straightedge on top. The glue spreads and hardens at the proper thickness to provide perfect alignment. Apply the glue to only one or two points at a time to prevent it from hardening too quickly. Waxing the cast iron tabs that the plate sits on ensures that the glue will stick to the plate instead of the tabs.

—Cam McIntyre,

Moose Jaw, Saskatchewan

CONTINUED ON PAGE 20

## Drawer Squaring Frame

I make a lot of drawers in my shop and got tired of fiddling with squares and pinch rods to square up the boxes during assembly. I decided to build a squaring frame to make the job go much quicker. It's really nothing more than an accurate 90° corner against which I can press the assembled drawer parts to square them up.

Glue and nail plywood strips together, alternating corner overlap

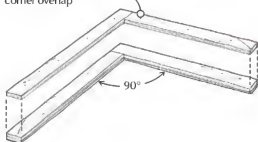

For quick, strong construction, I made the frame from six 2" x 18" strips of 1/2"-thick Baltic birch plywood, creating the corner joint by simply overlapping alternating pieces. I glued the layers together, clamping the two legs perfectly square to each other before driving in finish nails along the legs and at the corner. After the glue dried, I chamfered the bottom of the inner edge to create clearance for dust and chips. Then I drilled screw holes

for attaching the unit to my bench.

For assembly, I screwed the frame to my bench, then push a glued-up drawer corner against it. Because the frame is screwed fast, I can tap on a drawer corner with my mallet to bring it into square before installing screws, nails or other fasteners. If necessary, drawers can be clamped against the frame to dry overnight.

— Keith Miller, Aberdeen, South Dakota

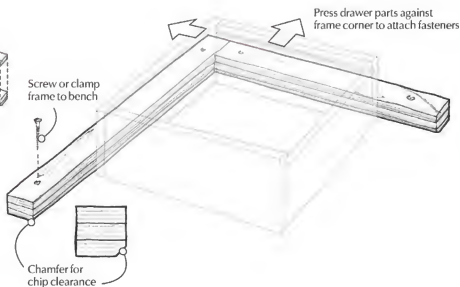

## Magnetic Stop-block for the Table Saw

When crosscutting a series of short pieces from a longer board using the table saw's miter gauge, it's dangerous to use the rip fence as a stop. The freed pieces can get jammed between the blade and fence, causing kickback. To prevent this, the usual approach is to clamp a wide "standoff" block to the rip fence to serve as a stop-block. That way, there's a recess between the blade and fence for the offcuts to go.

The problem with this approach is that even with a wide standoff block, the recess can fill up pretty quickly, forcing you to shut off the saw to clean away the accumulation of offcuts. To eliminate this problem, I use my dial indicator's magnetic base as a stop-block. I initially position the base with it pressed against my rip fence, which squares it to the end of the workpiece. After magnetically locking the base to the table, I slide the fence away so there's nothing restricting the offcuts.

One glitch I encountered was that the rough powder-coat paint job on my magnetic base caused balky forward movement of the workpiece. To fix that, I simply applied a short section of self-stick measuring tape left over from a jig project. **PW**

— Amy Nielsen, Maple Valley, Washington

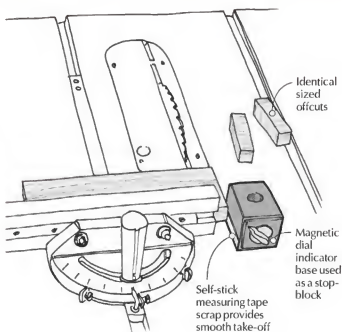

# 18th-century Chairmaking

## Building a 'Rush Bottum'd Chaire' – PART 2

In the last issue of *Popular Woodworking*, I began making my first chair. I turned the back legs, and I shaped and bent the slats to make a "ladder-back" type chair. I admitted that I was a bit reluctant to try chairmaking. I felt the joinery was too complex for my skills. In this article, I'll complete the chair frame's joinery and we'll see how I did with the challenging joinery.

### How this Species Survives

The basic structure of these chairs consists of turned legs, rails and stretchers. Legs are bored to receive the rails and stretchers. The ends of the rails and stretchers are turned down to form tenons. Crisp shoulders help ensure tenons reach full depth during assembly. The

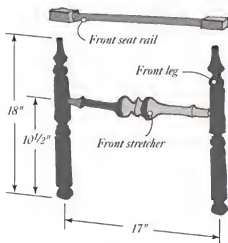

**Atypical details.** The basic joinery is not difficult. I chose a slightly more complicated version, however. In the diagram above, notice that the legs tenon into the front seat rail from underneath. This is not the most typical design. Generally the seat rails all tenon into the front leg, which then protrudes slightly above the seat. I chose this design because I thought it looked a little more refined, and I enjoy mixing refined features with cruder elements or textures.



**A common seat.** This "rush bottomed" chair probably represents the most common form of seating in 18th-century America. It's relatively simple and quick to build. Late 19th-century factory-made chairs went a long way to destroying the reputation of these otherwise admirable chairs. In this article, I'll finish my chair using the joinery and tools employed to build the originals.

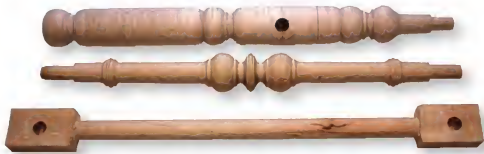

**Ready for assembly.** The front legs (top), front stretcher (middle), and front seat rail (bottom) are ready for assembly. Tenons have been turned but their ends will need to be rounded to clear the round-bottomed hole left by the spoon bit. The rectangular sections on the ends of the seat rail are called pommels.

parts are glued together with hot hide glue. This may be an important design feature. These chairs do tend to come apart with age. A reversible glue, a glue that can be reacted with more of the same, a glue with some gap filling properties, may be the key to these chairs' long-term survival.

### Why the Fronts are Fancy

There are a variety of different styles of leg and front stretcher turnings. In general, I think these chairs were stored against the walls of the home, not tucked around a dining table, so chair fronts were visible and an obvious location to add ornamentation. Delaware Valley chairs often exhibit exaggerated and bulbous versions of the front stretcher. Leg turnings are fairly simple, featuring beads and coves with a little vase on top. Interestingly, very similar leg turnings would find their way onto Philadelphia's first Windsor chairs. Likewise, the way the front legs tenon into the front seat rail reminds me of a Windsor chair. I usually think of the Windsor chair as a highly innovative and revolutionary (forgive the pun) furniture form. But I think this design suggests that Windsor chairmakers were influenced by earlier pieces just like everybody else.

### Building the Front

In my last article, I included a diagram showing the locations of the side stretchers at the back legs. In my observation of period chairs, it appeared these stretchers were always parallel to the floor. So I used those measurements for the front legs. I placed a bead and cove 1" above each of the side stretchers. The tops of the front legs featured a shouldered tenon. I was curious if these were ever tapered like Windsor chair seats. I haven't seen any evidence of that yet. So make them cylindrical like all the others.



**Whatever works.** I don't think the size of the pommel matters. Do whatever looks good to you. I marked in from the centerline of the leg about 1 1/4". I trimmed the outside edge just a little proud of the rush.

The front center stretcher was turned next. Its overall length was about 18". This length allowed 1 1/4"-long tenons. I determined the shoulder-to-shoulder dimension by subtracting the leg diameter (approximately 1 1/2") from 17" (a dimension that I got from measuring numerous period chairs).

The front seat rail was next. I sawed out a piece of maple 1" thick x 1 1/2" wide x 19 1/2" long. I purposely left it long so I could saw off the lathe centers and trim it nicely to the seat's

shape. The leg positions were marked and locations of the pommels were established. Then it was back to the lathe to turn down the portion between the pommels.

### Joint Quality: Not Too Tight

With all four parts done, I glued up the chair front and set it aside. Concerned about joint integrity, I first made very tight-fitting tenons. My tenons were so tight that I needed to twist the parts to get them in. This proved too tight



**Come together.** With the front and back of the chair completed, all I have to do is join them together. Getting the angles and locations correct is simple if you are careful.

for hide glue. The hot glue either swelled the wood or was too grabby to allow assembly of the parts.

Make sure you turn your tenons so that they can be installed with just hand pres-



**A big bottom.** I measured a number of chairs. Back legs were often no more than 13-14" apart. The depths of the seats were often 16" or more. I found this a bit surprising. I thought the seats would be shallower. I think a longer seat makes a chair a bit more comfortable to slouch in. The distance between the front legs was about 17".



**Easy to find.** You could make a scaled or full-sized drawing, or a template to help you build your chair. But I prefer to do what Kaare Loftheim does in Colonial Williamsburg's Cabinetshop. I lay out the dimensions on my work benchtop. Your benchtop is a convenient place for project plans and they are harder to lose. I'm guessing many of you won't take this advice! And I just planed this bench!

sure, pushing straight in. Tenons dry fit this way will probably need the help of a mallet to go together with hide glue. I also think it's important to fit the tenons and glue them up in one day.

One more trick: Determining the overall length of the rails and stretchers isn't just about ensuring maximum tenon length or being frugal with your material. When the turning stock is at its full length, the lathe centers are preserved in the finished piece. This allows you to turn down a tenon that's just a little too fat or trim away a shoulder to make the fit just right. The alternative is you saw off the lathe centers prior to dry fit and find some other way to take a uniform 1/2" off a tenon. Some guys sand their tenons. But the lathe is just so much easier for this sort of work.

As cabinetmakers, we develop dimensions (or not), mark them on our work, then cut to the line. But this chairmaking is different. The dimensions are used to derive what we really need – angles to set our bevel gauge to guide the boring of holes, and overall lengths and

shoulder-to-shoulder dimensions for the rails and stretchers. We can find all this mathematically, but I prefer to simply draw it out full size, then use the drawing to mark the parts.

### Intersecting Tenons?

The need to create a somewhat flat seat necessitates some compromise at the seat rail connections. You have two choices: You can either make the tenons short enough so that they don't intersect (like a cabinetmaker would) or you can allow a small 1/2" offset between the rails and intersect their tenons. The former approach would probably result in a weak chair. The latter is what was typically done.

I think the forces acting on a chair are front to back (introduced at the seat, reacted at the floor). This causes racking at the side seat rails and stretchers. Because of this, I think you need very good joint quality at these locations. This also tells me that, given the choice, it's wiser to compromise the front and rear seat rails and let the sides remain whole. Sorry if this is too technical. Our ancestors probably had a century of practical experience in forming such decisions. In my case, keeping the side rails and stretchers as strong as possible determined my assembly sequence. I built up the front and back of the chair. I laid each flat on the bench, then bored the angled holes for the side pieces.

With all the holes bored, I did a test fit (always a good idea). I tried to rotate each of



**Inset the rail.** I've got the front built up and you can see I've scribed the leg's centerline onto the back of the seat rail. Positioning the rail carefully, I see that the side rail must be inset if its centerline is to intersect the leg's centerline. If you've followed me, that's it. This is as tricky as it gets. I've made a mark indicating where I must start the hole for the side stretcher. All I need to do now is bore the right angles in the right spots.

the rungs. Any rail or stretcher that would not budge went back to the lathe. I guess I'm accustomed to working with hot hide glue because the glue up was uneventful. You brush on the glue and put the chair together.

### Wrapping it Up

There's primary source evidence that these chairs were painted a wide variety of colors. Black was fairly common, so I chose that. I tried my standard recipe of milk paint followed by oil and wax. That looked pretty good. But I also tried a semi-gloss rust preventative (hint hint) enamel thinking it would be closer to the originals' shiny oil finish. Frankly, both finishes looked fine and the enamel was easier. So I chose that.

I promised I would show you how to weave the seat. I have to break that promise. I used a commercially available pre-twisted natural sea grass rush. I needed 2½ rolls and the process took about three hours. A 17th-century document indicates seats could be woven at

a rate of nine per day. Obviously, they knew something I don't. Turns out there are many different ways of weaving a seat and twice as many different materials. If I come up with something you can't find on the Internet, I'll post it to my blog.

### Small Changes; Big Differences

I feel I can be brutally honest with you: I'm not crazy about this chair. There's too much curvature in the back slats for me to be comfortable. I chose a 30° mortise angle, which, in retrospect is too high for someone my size. I designed a five-slat chair, but built a four-slat chair to save time riving, shaving and forming. That was a big mistake. The slats are just too far apart. I think the legs are too thick. I should have turned them down another 1/8" and added more taper. And yes, I think an 1/8" really does make a noticeable difference. And the front stretcher should be 50 percent larger in diameter. Overall, I think the chair just lacks a certain pop.

Like so many prior articles, I focused this one on the process, exploring the joinery in particular. In that, I was successful. I bored good holes. Turned good tenons. Built strong chairs. I prepared my tools carefully and practiced my technique. But if what I make isn't beautiful, isn't comfortable, its tight joinery ceases to be a virtue. **PW**

*Visit Adam's blog at [artsandmysteries.com](http://artsandmysteries.com) for more discussion of traditional woodworking techniques.*



**No wiggle room.** Tight-fitting joints leave no room for error. Force a stretcher into a hole, and the chair can rack out of shape. I expect experience will teach me how to deal with problems like this one in more elegant ways. I chose to let the rear stretcher be where it wanted to be and introduce no weird internal stresses. It's very obvious in this view, but much less so in every other.



**Boring work.** I'm boring the hole in the back of the front seat rail for the side seat rail. The distance between these stretchers is just enough for me to swing my brace. I like having the stretchers in place so I can check the angle of the hole I'm boring. Photos are cruel masters. Looks like the first hole I bored was good and the successive holes stand up a little bit. I'd like to say this isn't a problem. But I may have to make the other side similar and force the seat rails the same amount on both sides to fit the chair back.

### Spoon Bits

Spoon bits are tricky to use. These old flat-tang bits had to be carefully mounted in bit "pads." It's important to note that the flat tang is not centered with the bit, but off to one side. New, square-tang bits don't have this problem. For this sort of chair, a 3/8" bit is required and possibly a small one, maybe 1/4" (or less) for pegs or boring holes for the slat mortises. The advantages of the spoon bit are that it's easy to change its direction, allowing fairly fine adjustment of the angle of a hole during drilling, and its round bottom. This feature lets you bore almost through a post, providing for maximum tenon length. One thing to watch for when using a spoon bit is that they don't eject chips. So you can be cranking away waiting to see some progress only to find you've bored too deep a hole. Check your hole depth frequently.

—AC



# The Magic of Masking Tape

Find magic in the mundane using this humble problem solver.

One of the most important lessons I've learned as a woodworker is to never underestimate the seemingly mundane. I have found great utility in common household materials: old Tupperware, measuring cups, shell liner, string, Dixie cups and old T-shirts, just to name a few. But here's a fair warning: Don't take these items out of the house without permission. Certain family members might not appreciate their favorite coffee grinder being used to pulverize shellac flakes!

One item, however, deserves to be purchased specifically for your shop and stands out as the ultimate multi-tasker – masking tape. Just when I think I have exhausted its list of uses, I come up with another way to incorporate the sticky stuff into my workflow. As a result, I buy this stuff by the case!

## Origins of Masking Tape

To understand the real magic of masking tape, we should first learn about its origin. Masking tape was invented by the 3M company, in 1925, at a time when the company's primary business was abrasives.

A clever employee, Dick Drew, saw a need for a less aggressive tape in the automotive painting industry, and realized his company already had two of the key ingredients, which are paper and adhesive. Soon after, rolls of this moderately sticky paper were being mass-produced and they soon found their way into homes and shops everywhere.

So here is a quick introduction to some of my favorite woodworking shop uses for mask-



**Buy it by the case.** Masking tape, a multi-tasking workhorse in the shop, has earned a place of importance hanging on my tool rack. Take it out of your drawer – it's not just for painters anymore.

ing tape. Although you can use regular masking tape for most of these tasks, my preference is for the blue painter's variety. It holds well and leaves little to no residue. The green tape works well too, but I reserve that for special applications where I need increased holding power and greater chemical resistance.

## Hiding from the Finish

The one function of masking tape that should be obvious is, of course, masking. When creating a two-tone finish, proper masking is

essential. I most often use blue or green tape, along with brown paper, to protect specific areas from the accent color.

For most woodworkers though, the most useful type of masking comes into play while applying finish on projects prior to assembly and during assembly. On some projects, it just makes more sense to finish the components prior to the glue-up. The risk we run, however, is getting finish on our joinery. The finish seals the wood and the result is a much weaker glue bond.

## Online EXTRAS

To watch a video of The Wood Whisperer as he demonstrates these masking tape techniques in his shop, go to:

[popularwoodworking.com/aug08](http://popularwoodworking.com/aug08)





**Peel away problems.** A strip of blue tape protects the inside of the groove from finish materials and keeps the fit tight.



**Thrifty clamps.** Stretch the tape over the edging with as much pressure as possible. The more stretch, the more holding force.



**Shot through the tape.** Masking tape ensures any wood filler is directed into the hole only and not into the surrounding wood pores.

To prevent this, I use masking tape to protect the joinery from any finish. Dados and rabbets can be protected with a long piece of tape; tenons can be protected by a full wrap.

Now whether you add finish before you assemble your work or not, glue squeeze-out is always an issue. By masking off all your joints with tape during a dry fit, you can easily protect the surface from that inevitable wayward glue at final glue-up.

### The Quickie Clamp

Anybody who's tried to attach solid wood edge-banding to casework knows how tricky it can be to secure the banding while the glue dries. Edge clamps aren't cheap, and you don't always want to use brad nails.

By stretching a 4" to 5" piece of masking tape over the edging, you can achieve a reasonable amount of clamping pressure. Place a strip every few inches along the length of the board, and you are on your way to nice, solid wood edges without taking out a second mortgage for 30 edge clamps.

### Perfectly Filled Holes

Many woodworkers are big fans of brad nailers. And why not? They make quick work of attaching trim of all shapes and sizes. A major drawback is the hole that remains after the nail is driven through the wood.

In most cases, the filler not only fills the holes, but it also penetrates surrounding pores in the wood. Unfortunately, this spot usually reveals itself once the finish is applied. How can we prevent this? Next time you pull out the brad nailer, try applying small pieces of masking tape everywhere you plan to shoot a nail. Then just shoot right through the tape.

Keep the tape on while you fill the hole with your filler. Once the filler is dry, remove the tape and you'll see a nice tidily filled hole.

### Veneer Clamp

When veneering, it is frequently necessary to attach multiple pieces together along their thin



**Veneer tape with a kick.** Stretch tape over a veneer joint, then as the tape shrinks back, the butted veneers come together tight and secure.

edges in order to get the width you require, just like with solid wood. But unlike solid wood, it's hard to secure the two pieces of veneer with clamps. So I like to stretch pieces of masking tape over the joint every 3" to 4", stitching it together as I go.

The tape has the ability to stretch and spring back, so you can use that to your advantage. Securely attach the piece of tape to one end, then hold it down with your finger while stretching the other end over the joint and secure it to the other side. When you let go, the tape shrinks back just enough to close the gap and hold the two pieces securely together.

### Tear-out Reduction

As many woodworkers have discovered the hard way, both plywood and solid wood have a tendency to tear out during crosscuts. Sharp blades and zero-clearance inserts can help, but sometimes these options aren't available to us or they are just not effective enough. In most cases, with a little extra support during the cut, the fibers will remain intact.

Once again, masking tape to the rescue! By laying down a strip of masking tape on the cut line, the fibers are completely supported dur-



**Smooth out a cut.** Masking tape significantly reduces the amount of wear-out caused by an aggressive jigsaw cut.

ing the cut and the cut quality increases dramatically. This trick is especially useful when cutting expensive plywood with a jigsaw.

These are just a few examples of the many nifty "magic tricks" you can do with masking tape. Is it a cure for all that ails ya? Nope. Will it take all the dust nibs out of your finish? Not likely. But you will be surprised by just how many things it can do.

So the next time you're faced with a dilemma and you're at a loss for a solution, look around—it's not difficult to find magic in the mundane. The answer might be found in a simple roll of tape. Just don't tell the tape company because they'll raise their prices. **PW**

Marc is a professional woodworker as well as the creator and host of *The Wood Whisperer* ([thewoodwhisperer.com](http://thewoodwhisperer.com)). *The Wood Whisperer* (an instructional internet woodworking show) represents Marc's three passions: woodworking, technology and education.

### About This Column

Our "Wood Whisperer" column features woodworking thoughts and ideas, along with shop techniques from Marc Spagnuolo. Each column has a corresponding video related to the techniques or views expressed in the column available at [popularwoodworking.com/video](http://popularwoodworking.com/video).



# Contemporary Bookshelves

Two tones of color and sharp, square edges give this piece modern flair.

Inspired by a design in the February 2008 issue of the German magazine *Selbst*, this "I Can Do That" project commenced (as always) with a pilgrimage to the home center, where I picked up four 6' 1x12s and one 6' 1x6 of red oak, and a bag of red oak plugs.

Because there are no curves and no long rip cuts, this piece is ultra-simple to build. The trickiest operation is notching out the upright that will be stained black... and that's not tricky at all.

It's always a good idea to ensure the ends of your boards are square, so first trim a small amount off one end of all your pieces at the miter saw, and mark the cut ends.

Now you're ready to get started. Set up a stop  $31\frac{1}{2}$ " to the left of the saw blade as shown in the picture on the next page. Butt the trimmed end of one 1x12 against the stop, cut your first shelf, then repeat three times. Move the stop to  $37\frac{1}{2}$ " and cut the matching top and bottom pieces. Your final crosscuts are on the two side pieces, at 58" (again, but the ends you've trimmed against the stop so that both ends will be square after the cuts).

Lay the 1x6 (which is actually  $5\frac{1}{2}$ " wide) flat and mark the four notches for the shelves. Theoretically, each notch should be  $\frac{3}{4}$ " thick (the thickness of your stock), but because you still need to sand the shelves, you may want to cut the notches a hair under that—or sand all your pieces to #120 grit first, and use the final thickness as your marking guide. Each notch is  $1\frac{1}{4}$ " deep, marked per the drawing.

Now clamp the 1x6 flat to your Workmate and use a jigsaw to cut out the notches. To minimize blade deflection, use a heavy blade for the  $1\frac{1}{4}$ "-deep cuts, then switch to

**Two-toned appeal.** Different colors of wood, simple lines and sharp, square edges give these easy-to-build bookshelves a contemporary flair.



a fine, narrow blade to make the  $\frac{3}{4}$ " cuts at the end of each notch. You may have to use a rasp to clean up the cuts after jigsawing, as you need them to be flat on all sides, and fit snug to the shelves. (For more information on cutting notches with a jigsaw, see *Popular Woodworking* August 2006, issue #156, "Egg Crate Shelves.")

Lay the notched side piece atop the interior face of the wide side piece with the top and

bottom aligned, then mark the notch locations on the wide side to show the location for the screws. Set the notched piece aside. Use a combination square to mark the shelf lines across the wide piece and mark for three screw holes across each shelf location. Drill the clearance holes with a  $\frac{1}{8}$ " bit, then flip the piece over. Using your already drilled holes as a guide, drill countersinks at each hole location on the outside face.

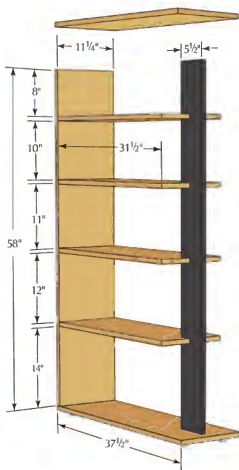

## CONTEMPORARY SHELVES

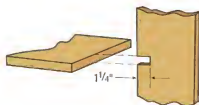

NOTCH DETAIL

Now find a flat surface on which to rest one end of the wide side piece, then clamp a shelf into your Workmate and lay the side piece across it (interior down), carefully lining up the shelf with the lines you've marked on the side. The side piece serves as a location guide to drill  $1/8$ " pilot holes into the shelf. Now sink  $1 3/4$ " screws into each hole, securing the shelf to the side. We recommend McFeeley's or Spax "premium" wood screws; both are available at [mcfeeleys.com](http://mcfeeleys.com) or 800-443-7937.

Attach the remaining three shelves in the same manner. (You may need help to reposition the workpiece as you add the shelves; it gets heavier with each one.)

After the four shelves are attached, lay the piece on its side on a table (shelves pointing up), and scoot it to the end of the table so you have room to easily manipulate your drill. Balance the top piece at the top edge, and drill three pilot holes through the top and into the side. Then drill countersinks into the pilot holes in the top, and set the screws. Do the same at the bottom.

Line up the notched side at the center, drill two pilot holes and countersinks at the top and bottom, and set the screws.

## Contemporary Bookshelves

NO.	ITEM	DIMENSIONS (INCHES)			MATERIAL
		T	W	L	
1	Top	$3/4$	$11 1/4$	$37 1/2$	Oak
1	Bottom	$3/4$	$11 1/4$	$37 1/2$	Oak
4	Shelves	$3/4$	$11 1/4$	$31 1/2$	Oak
1	Wide side	$3/4$	$11 1/4$	58	Oak
1	Narrow side	$3/4$	$5 1/2$	58	Oak
4	Feet	$1/2$	1	1	Scrap



**Countersink bit.** The top of this countersink bit drills a hole with angled sides, into which a screw head seats so that it's flush with or below the surface of your work, depending on how deep you drill the countersink.

Once you're sure everything fits together well, remove the notched piece and finish as desired. I used two coats of Cabot's ebony stain. After the stain was completely dry, I reinstalled the notched side, glued and tapped in plugs to cover the screw holes on top and sanded them flush, then finished the entire piece with two wiped-on coats of Watco Danish Oil in natural.

Unless your notches are very snug, you'll need to "toenail" the shelves from the undersides to the notched side piece, to keep each shelf firmly in place. (Toenailing is simply a nail set at an angle through two pieces.)

Finally, make four  $1" \times 1"$  feet out of pieces of scrap (I used  $1/2$ " plywood) and nail them to the bottom, about  $1"$  in from the corners.

A final note: With any heavy and tall piece, it's necessary to secure it to the wall before loading it up. **PW**

Megan is the managing editor of this magazine. Contact her at 513-531-2690 x1348 or [megan.fitzpatrick@fvpubs.com](mailto:megan.fitzpatrick@fvpubs.com).

## About This Column

Our "I Can Do That" column features projects that can be completed by any woodworker with a modest (but decent) kit of tools in less than two days of shop time, and using raw materials that are available at any home center. We offer a free online manual in PDF format that explains all the tools and shows you how to perform the basic operations in a step-by-step format. You'll learn to rip with a jigsaw, crosscut with a miter saw and drill straight with the help of our manual.



Visit [ICanDoThat.Extras.com](http://ICanDoThat.Extras.com) to download the free manual.



**Clamped stop.** Making multiple cuts of equal length at the miter saw is made easier by measuring just one piece then clamping a stop-block to the fence. Then, instead of measuring and marking each cut, you can simply butt the squared stock against the stop.

# 24" Omnijig Joinery System

Porter-Cable's solution to jig-cut joinery does the job, but it requires an additional outlay of funds to become a fully functioning system.

When I opened the box the first object in sight was the manual. Is Porter-Cable making a point by placing the manual at the top of the box? After a good look at the Omnijig joinery system (#77240), you might think so.

I looked through the manual—which has very clear instructions—pulled the jig from the box and was all-but-ready to make dovetails. There's nearly no setup with the Omnijig, just position the stops, then attach the router-bit depth pod.

At first look, this tool appears complicated and quite different from other available dovetail jigs. Stops are used to locate the finger template, one on each end of the jig. But otherwise, the Omnijig operates like other well-known dovetail jig designs.



**Creative stops.** Omnijig stops, used to position the templates, were calibrated correctly for straight-from-the-box use, but can be fine-tuned.



24" OMNIJIG Joinery System

Porter Cable • 866-375-6287  
or [deltaportercable.com](http://deltaportercable.com)

Street price • \$600

For more information, circle #149 on Free Information Card.

The fingers are adjustable to determine pin width as well as spacing along the width of your project. Loosen a square-drive screw, gently rock the finger to release its grip on the template, then position each half-finger to your desired location. Make sure to snug the screws when positioned. It's possible for the fingers to move while routing if they're not firmly tightened.

As with most jigs, there are pros and cons. Single-lever clamping is a very nice feature—once the clamping bar is set, it's a simple flip to hold the workpiece in position. This also allows you to have one hand on the board as you release the jig's hold. I'm impressed with how the stops work and with the factory setting being exact, although you can tweak the stops if need be. In addition, the router-bit pod is a great idea. Set a router with the proper bit installed onto the pod to accurately adjust the depth of cut.

Evaluation of the opposite side of the equation starts with what's not included with the jig system. You'll pay extra to cut through-dovetails in thicknesses other than  $\frac{3}{4}$ " (only one dovetail router bit is included with the jig), or produce box joints, sliding dovetails and thinner pins (down to  $\frac{1}{4}$ " in width). There's

an additional charge for jig-designed dust collection and of course, you're limited to a 1:8 dovetail slope.

I took a test drive straight out of the box, creating both through-dovetails using  $\frac{3}{4}$ "-thick material and half-blind dovetails, joining  $\frac{1}{2}$ " drawer sides to a  $\frac{3}{4}$ " drawer front. The fit of the through-dovetails was snug and exact. The half-blind, variable-spaced dovetails fit perfect. No tweaking was required, but fine adjustments are easy to make.

The Omnijig is not a magic bullet for making dovetails and other joinery. Your cuts need to be square just as with other dovetail jigs. You have to prepare your parts to the proper thickness and you have to select the right bits, bushings and settings to make good-fitting dovetails. If using a jig is your path to dovetails, the Omnijig will do the work. But, you'll shell out more than just the initial cost to gain a full repertoire for woodworking.

There is also a 16" Omnijig joinery system that features different accessories. See the company's web site for details.

—Glen D. Huey

CONTINUED ON PAGE 32

PHOTOS BY AL PARRISH

## Brese Planes: Custom Details at a Fair Price

I don't think there's a tool out there that has a wider range of prices than a smoothing plane. You can pick one up for \$5 at a flea market, spend a few hundred on a Lie-Nielsen or Veritas, or drop \$5,000 on a Karl Holtey.

For those woodworkers who want all the benefits of a custom in-fill plane (so named because it's a metal shell filled with wood), but can't justify the top end, there's Ron Brese.

Brese's planes look fantastic and work at an extremely high level. But the price tag is lower: \$500 to \$1,300 on average. I tested one of his 800-255 smoothing planes with the iron bedded at 55° for a few months, and here are some of my impressions.

The body is an enormous chunk of brass, with 1/4" sidewalls that are riveted to the 3/8" brass sole. Riveting requires less labor than dovetailing, and it produces a remarkably strong shell. The metalwork is very nice – on par with many of the other custom planes I've seen, with tight joints and fair chamfers.

The walnut in-fill in this 8"-long plane is just

about perfect, which is no surprise because Brese is a talented furniture maker.

In fact, I think his skill at woodworking has clearly helped his toolmaking skills. This tool is eminently suited for smoothing difficult woods. Its tight mouth, steeply pitched 1/4"-thick iron and solid construction allowed it to plane everything we threw at it, from severely interlocked mahogany to curly maple to cherry with a lot of reverse grain. This isn't an everyday smoothing plane – it is the tool you call in when your regular smoothing plane won't do and you don't want to sand.

My only quibble with the tool is there is no proper way to retract the cutter with hammer taps. I wish the iron had a full neck – a horizontal bar of metal – which would make the iron easier to retract.

All in all, I was extremely impressed with the Brese plane – its stunning looks, its craftsmanship and its outstanding performance. This is definitely a tool for your short list.

— Christopher Schwarz



### Brese 800-series Planes

Brese Planes • 706-647-8082 or  
breseplane.com

Street price • \$1,285

For more information, circle #150 on Free Information Card.

## Bosch Jigsaw: Good Performance With Minimal Investment

From cutting a fancy apron on a high chest to breaking down lumber for a project, jigsaws tackle many jobs around the shop. But for the average woodworker, a jigsaw is not going to be the most-used tool in the cabinet. Why spend a considerable amount of your tool budget for such a saw provided you could find a reasonably priced – if not downright inexpensive – equally capable jigsaw?

That's exactly the jigsaw Bosch – the leader in the category – has launched with the JS5. It's a 5.7-amp, variable-speed jigsaw with four orbital settings. The JS5 features Bosch's "One Touch" tool-less blade changing system. There is a rubberized grip for comfort and a blower switch to clear debris from a cut – or you can leave the blower off and connect the jigsaw to an optional vacuum hose through a rear-vented dust port.

The variable speed is adjustable in two ways: via a dial located near the back of the saw or by the amount of "squeeze" you apply to the trigger. I find setting the speed with the dial the best. Then I can fully squeeze the trigger (six speed settings allow you to fine-tune the cut for different tasks) and make use of a "lock-on" button located adjacent to the trigger, which holds the saw in the on position as

you cut. A tap of the trigger releases the button and stops the saw action.

Changing jigsaw blades with a simple flip of a lever is the only way to work. Bosch's system is entirely user-friendly. Push the lever to its center stop, insert a blade set in the correct position and let go of the lever. To remove a blade, push the lever to the center and the blade pops out.

The JS5 has a rubberized grip for use as a top-handle saw. But this jigsaw also has that same grip applied to the body of the tool. This suggests you can use the jigsaw as a barrel-grip saw as well, but I found that gripping the body was somewhat uncomfortable, and I had a tendency to prematurely hit the tool's lock button, releasing its hold.

One aspect of the JS5 that we are less than enthused about is the stamped base plate. It would be better to have a cast plate to offset any unexpected drops resulting in a bent base.

The JS5 jigsaw made cuts just as any higher-cost saw would. Whether we cut following a straight line or sawed a circular path, this jigsaw felt well balanced in our hands and performed the work without problems. I would select this jigsaw for the shop and apply the savings to another tool.

—GH



### Bosch JS5 Jigsaw

Bosch • 877-267-2499 or  
boschtools.com

Street price • \$107

For more information, circle #151 on Free Information Card.

## Infinity's Professional Coping Sled

If you're building a number of doors for cabinets or cupboards, and you're not employing traditional construction techniques, you're most likely using cope and stick (rail and stile) router bits at a router table.

The most difficult cut to make using these bits is, of course, the coped portion. This cross-cutting action is repeated twice on each rail; if you're not using a backer piece as you make a cut, you're wasting material when you blow out the back edge of the cut.

You need a coping sled. Infinity's Professional Coping Sled is the right tool. Constructed with a  $\frac{3}{8}$ "-thick aluminum base that dampens vibration (the base now comes tapped for adding a miter bar if you so choose) and soft-padded ergonomically designed handles, this sled is designed to be used for extended periods of shop time.

Three fully adjustable toggle clamps are positioned for accurate workholding; two hold the workpiece from behind a fixed fence while the third is set on an adjustable fence to be properly positioned depending on the width of your stock—up to a maximum of  $5\frac{3}{4}$ ". That covers most door applications.

When designing the Professional Coping Sled, safety was obviously important. Infinity implemented a  $\frac{3}{16}$ "-thick Lexan visor that



Professional Coping Sled

Infinity Tools • 877-872-2487 or  
infinitytools.com

Street price • \$140

For more information, circle #152 on Free Information Card.

runs the length of the sled and rides against a fence. This keeps the sled square to the router fence and completely away from spinning router bits while maintaining a clear view of the cutting action. However, we have a router table fence in our shop on which a T-track is in the same location as the visor. This could affect the sled's safety execution—but is easily corrected with an auxiliary fence.

Where I found this sled to work best is

when no miter-gauge slot is available. Due to the visor sliding along the fence face, it's possible to make accurate cope cuts each and every time. The sled locks the stock firmly and allows a perfect cut. —GH

## Norton's Sharpening System in a Box

I'm not the most organized person in the world and this is one of the reasons I like the Norton IM83-W Sharpening System. In one case, which is just a bit larger than a lunch box, is everything I need to keep my edge tools honed and sharp.

In the top of the box is a three-sided gizmo that holds three waterstones: #1,000, #4,000, and #8,000 grit. It is designed to hold two of the stones in a bath of water, and the third in position for use. As I move up through the grits, rotating the holder brings the next stone into position, soaked and ready to use. I don't have room for a dedicated sharpening station, or the discipline to keep myself from piling stuff on one if I had one, so this makes it easy to contain the mess when it's time to hone, and it only takes a minute to pack it all back up.

I like the Norton waterstones because they are abrasive enough to cut quickly, but soft enough to provide useful feedback while

sharpening. Some people find the #4,000- and #8,000-grit stones to be too soft; it is possible to poke a corner of the tool into the stone.

In the bottom of the box is a second storage compartment where a flattening stone lives, and there is space down there for a few rags and other sharpening sundries. Bringing the stones back to a flat surface is quick work with the flattening stone, and the stones are 1" thick. It would take a truly obsessive sharpener a long time to wear one out, but it is possible. My conclusion is that Norton has reached a good compromise with the composition of these stones. They cut fast, leave a keen edge and can be easily maintained. Having the complete set in one handy box that fits in a small space is a plus. The kit sells for about \$200 from many retailers, and is also available with oilstones instead of waterstones. I think it's an excellent solution for sharpening. **PW**

—Robert W. Lang



Norton Sharpening System

Norton • [nortonstones.com](http://nortonstones.com)

Street price • \$225

For more information, circle #153 on Free Information Card.

# Wayne Anderson Smoother

A high-angle tool of last resort, this small plane can go anywhere and plane almost anything.

**D**espite the amount of bronze, iron and beech in my tool cabinet, most woodworkers need only three bench planes: A fore plane to reduce the thickness of boards, a jointer plane to flatten them and a smoothing plane to prepare them for finishing.

That's in a perfect world. In reality, we work with a material (wood) that is unpredictable, cantankerous and vexing—like my first red-headed girlfriend.

During the last few years, I've gradually folded a fourth plane into my arsenal, and now I cannot imagine working without it.

It's a small smoothing plane with a steeply pitched iron (a 57° angle of attack), no chipbreaker and a mouth aperture that a gnat would have a hard time squeezing through without damaging his Dipteran hinder.

This is my plane of last resort. When my 50°-pitch smoothing plane leaves nasty torn grain in its wake, I pull out this plane. It doesn't care if there's a grain reversal in the board. Or if I'm planing against the grain. Or if the grain is interlocked, curly or worse. When set for a fine cut, this plane almost never fails me.

This plane has become a staple of Wayne Anderson, a custom planemaker in Elk River, Minn. ([andersonplanes.com](http://andersonplanes.com) or 763-241-0138). This form of plane started out several years ago with Wayne's interest in high-angle planes



High-angle Smoother

Anderson Planes • 763-241-0138 or [andersonplanes.com](http://andersonplanes.com)

Street price • Varies

without a chipbreaker. He built this version for writer Kerry Pierce to test for a competing magazine. Then I bought the plane from Wayne. (Despite the fact that it was a used tool, I paid full price.)

Since that time, I've fallen head-over-heels for the plane, and Wayne has pushed the tool's design in new directions for other customers. If you're not familiar with Wayne's work, he's a bit different than other custom makers. He seldom makes the same tool twice.

The profile on the rear of the iron might change. Or the shape of the sidewall or lever cap will morph. But the tool still looks like itself—like a fraternal twin.

As to the function of the tool, you could set up a 6"-long block plane to do the exact same job, but there's no way the tool will look as good or fit your hand so well.

With this small smoothing plane, the coffin shape of the body lets you squeeze the tool right in the middle by its mouth. And having mastered the tool, I find I can change the depth of cut merely by squeezing and pressing at the center of the tool, or by releasing that pressure. The weight of the plane (2 lbs. 2 oz.) keeps the tool in the cut without chattering

(try that with your block plane) even when I use little-girl pressure to control it. The result: Thin shavings; no tearing.

The rear bun is rounded nicely so it feels good against my right palm, and the tall iron keeps my hand right where it should be.

The short sole (about 5 1/2") allows you to plane in areas that longer smoothing planes can't get to. When I say this I don't mean tight little spaces inside a cabinet, I mean the small and large hollows that occur on any flat board. A small tool rides the gentle waves of a board where a longer plane skims off the peaks instead. And when you're trying to get a tabletop looking right (perfect flatness be darned) a short plane is invaluable.

If you're thinking of investing in one custom plane, this plane would be an excellent addition to any standard lineup. These tools start at \$825. Need more convincing? Wayne has provided a slide show of the different forms of this plane during the last few years that you can download from our web site. I'll warn you, however, it's dangerous to watch. **PW**

## About Our Endurance Tests

Every tool featured in our Endurance Test column has survived at least two years of heavy use in our shop here at *Popular Woodworking*.



 Online EXTRAS

A SketchUp model of this project, as well as videos on lumber selection and making and using jigs for case construction, are available online at:

[popularwoodworking.com/aug08](http://popularwoodworking.com/aug08)



# Craftsman BOOKCASE



If something is worth doing, it's worth doing excessively.

BY ROBERT W. LANG

**T**here are many bookcases in my house, but they're a motley collection—poor cousins to the rest of the furniture. The really nice bookcases I've made have gone to live with clients, while I have kept the prototypes and the also-rans. They are nicer than concrete blocks and pine planks, but not my best work. The cherry bookcase in my living room was a test case—both of a dovetail jig and the wood's moisture content.

It was time for something nicer. This design is an adaptation of early 20th-century Gustav Stickley bookcases. I wanted to use nice wood, and show off a bit with the joinery.

I didn't have a specific species of wood in mind when I went to the lumberyard, but I knew I wanted something attractive and wide enough to avoid gluing up individual boards. I found a nice batch of sapele, also known as African mahogany, and brought home 50 board feet of wide planks.

## Off to a Good Start

My lumber had been surfaced to  $1\frac{5}{16}$ ", but it wasn't quite flat. After cutting the parts to rough sizes, I ran the material over the jointer and through the planer to remedy that, ending up with stock slightly thicker than  $1\frac{3}{16}$ ". I planed off the mill marks with a smoothing plane, and dressed all of the stock with a

scraper before working on the joinery.

This exercise served two purposes: I now knew the material was straight and true, and having the faces at a nearly finished state would save work later on. It's a lot easier to work on a plank on a bench than it is to work inside an assembled cabinet.

When the faces were smooth, I cut the sides and fixed shelves to their final sizes. I determined which side should be right and which should be left, situating the most attractive faces on the outside. I put a 1"-diameter straight bit in my plunge router, and set the fence to cut a  $\frac{7}{8}$ "-wide,  $\frac{1}{2}$ "-deep rabbet on the back edge of each side, stopping at the bottom edge of the lowest shelf.

Doing this step first established the sides as right and left, and it kept me from confusing the inside and outside faces as I worked on the remaining joints. Each of the three shelves connects to the cabinet sides with a pair of wedged through-tenons. On the inside of the case, each shelf sits in a  $\frac{1}{8}$ "-deep dado.

The dados aren't really needed structurally, but they ensure that the inner surfaces of the joints always look good, and they help to locate the through-mortises with the jigs that I used. With a dozen through-mortises to fit, I needed a method to make the process efficient and idiot-resistant, if not idiot-proof.

## Jigs and Joints Work Together

Because I didn't have a router bit the exact size to match the thickness of the shelves, I decided to use a  $\frac{3}{8}$ "-diameter,  $\frac{1}{2}$ "-long bit with a guide bearing mounted above the cutters. I made a jig to match the thickness of the shelves by clamping an offcut from one of the shelves between the two fences.

I then screwed a straight piece of scrap to one end of the fences, making certain that the inner edge was square to the working edges of the fences. I screwed another piece of scrap to the opposite end of the fences, and I was



**Dedicated jig.** This dado jig is made to fit the thickness of the shelves, and utilizes a flush-cutting bit with the bearing on top.

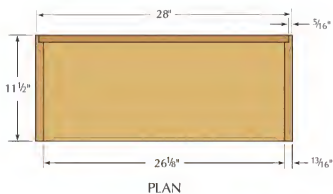

EXPLODED VIEW

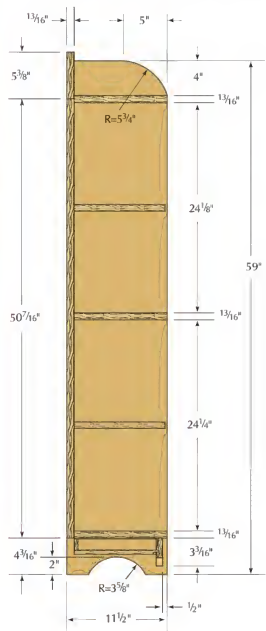

SIDE SECTION

ready to make a test cut. The resulting dado was just a bit narrow, and a few swipes with the smoothing plane on the bottom of the shelves made for a snug fit.

After routing the three dados in each of the case sides, I began to make the second jig, which is used to cut the mortises. The mortises are 5/8" wide and 2 3/4" long, and they are equal distances from the front and back of the case sides with a 3" space in between. Rather than cut the mortises in the jig, I made them by assembling pieces of 1/2"-thick plywood in two layers.

I laid out the locations of the mortises on the larger, bottom part of the jig, then I glued and nailed smaller pieces along the layout

lines. I drilled holes in the waste area, and with a flush-trim bit in my router, I trimmed the bottom of the jig to match the top. A few cuts with a chisel to clean out the corners and I was ready to make mortises—almost.

The mortises need to be exactly centered in the dados, and I needed a way for the jig to be clamped to the case sides. I made an edge piece the thickness of the case side, plus the thickness of the jig, and used the same jig that I used to cut the dados in the sides to cut a notch across this piece. This notch aligns the jig to the shelf dados.

After carefully centering this piece on the mortises, I screwed it in place and made a test cut. I used an offcut from one of the shelves to align the jig for routing. I jammed the offcut in the dado in the case side, leaving an inch or so protruding from the edge of the side. This allowed me to knock the notch in the jig over the scrap. With the jig properly aligned to the case side, I clamped it in place. After drilling a hole to get the bit started, I cut the mortises with a flush-trim bit in my router.

After routing each pair of mortises, I left the jig clamped in place, flipped the side over and used the jig as a guide to cut the corners of the mortises square with a chisel.

At this point, I walked away from mortise-and-tenon territory and went to work on the curved profiles at the top front corner of each side, and the arched cutouts at the bottom. After laying out the curves on one side, I cut close to the line with a jigsaw and cleaned up the edges with a rasp.

The first side was put into service as a template for the second. I put the finished side on top of the other and traced the curves.

## Craftsman Bookcase

NO.	ITEM	DIMENSIONS (INCHES)			MATERIAL	COMMENTS
		T	W	L		
□ 2	Sides	13 <sup>1</sup> / <sub>16</sub>	11 <sup>1</sup> / <sub>2</sub>	59	Sapele	
□ 3	Fixed shelves	13 <sup>1</sup> / <sub>16</sub>	10 <sup>11</sup> / <sub>16</sub>	28 <sup>3</sup> / <sub>8</sub>	Sapele	
□ 2	Adjustable shelves	13 <sup>1</sup> / <sub>16</sub>	10 <sup>7</sup> / <sub>16</sub>	26 <sup>1</sup> / <sub>4</sub>	Sapele	
□ 2	Back panel outer stiles	13 <sup>1</sup> / <sub>16</sub>	3 <sup>5</sup> / <sub>16</sub>	50 <sup>7</sup> / <sub>16</sub>	Sapele	
□ 1	Back panel inner stile	13 <sup>1</sup> / <sub>16</sub>	3	46 <sup>5</sup> / <sub>16</sub>	Sapele	1 <sup>1</sup> / <sub>4</sub> " TBE *
□ 1	Back panel top rail	13 <sup>1</sup> / <sub>16</sub>	3	23 <sup>1</sup> / <sub>4</sub>	Sapele	1 <sup>1</sup> / <sub>4</sub> " TBE *
□ 1	Back panel bottom rail	13 <sup>1</sup> / <sub>16</sub>	3 <sup>5</sup> / <sub>16</sub>	23 <sup>1</sup> / <sub>4</sub>	Sapele	1 <sup>1</sup> / <sub>4</sub> " TBE *
□ 2	Back panel middle rails	13 <sup>1</sup> / <sub>16</sub>	3	11 <sup>3</sup> / <sub>8</sub>	Sapele	1 <sup>1</sup> / <sub>4</sub> " TBE *
□ 4	Back panels	3 <sup>1</sup> / <sub>4</sub>	9 <sup>5</sup> / <sub>8</sub>	21 <sup>1</sup> / <sub>8</sub>	Sapele	
□ 1	Backsplash	13 <sup>1</sup> / <sub>16</sub>	5 <sup>3</sup> / <sub>8</sub>	27 <sup>1</sup> / <sub>2</sub>	Sapele	
□ 1	Lower apron/drawer front	13 <sup>1</sup> / <sub>16</sub>	3 <sup>3</sup> / <sub>16</sub>	26 <sup>3</sup> / <sub>8</sub>	Sapele	
□ 2	Drawer sides	5 <sup>8</sup> / <sub>16</sub>	1 <sup>3</sup> / <sub>4</sub>	10 <sup>1</sup> / <sub>16</sub>	Maple	
□ 1	Drawer back	1 <sup>1</sup> / <sub>2</sub>	1 <sup>1</sup> / <sub>4</sub>	26 <sup>1</sup> / <sub>8</sub>	Maple	
□ 1	Drawer bottom	1 <sup>1</sup> / <sub>2</sub>	9 <sup>3</sup> / <sub>4</sub>	25 <sup>3</sup> / <sub>8</sub>	Poplar	
□ 2	Drawer runners	3 <sup>1</sup> / <sub>8</sub>	3 <sup>1</sup> / <sub>4</sub>	9 <sup>1</sup> / <sub>16</sub>	Maple	

\* TBE=Tenon both ends



**Built around the holes.** This jig for the through-mortises is made by assembling small pieces to a backer. The openings are then cut with a router and a locating fence is added.



**Double duty.** After routing, the mortising jig also serves as a guide for the chisel to square the corners of the through-mortises.



**Getting in shape.** After cutting the lower arch with a jigsaw, the curve is smoothed with a rasp.



**One side makes another.** After the curves on one side are completed, the first side is used as a template to make the second side.

After cutting the curves in the second side, I clamped the two together, and used a flush-cutting bit in the router to make the second side an exact match of the first.

### A Trip to Through-Tenon Territory

The next step is where the dados in the case sides saved a tremendous amount of time and prevented the formation of even more grey hair. The layout for the tenons needs to match the mortise locations exactly.

At this point I looked at the three shelves, marked the best face and edge of each, and decided which one would be the top, mid-

dle and bottom. I clamped the entire cabinet together and with a lumber crayon, marked the locations of the shelves in relation to the cabinet sides.

Some hand fitting would be needed, and putting a carefully fit bottom shelf upside down in the top shelf location wouldn't be a good thing. With the case together, I ran the point of my knife around the perimeter of each mortise, marking the location of the tenons in the ends of the shelves.

I set up a small plunge router with a fence set to leave the tenons slightly proud of the outside of the cabinet sides. I set the depth

to the top of the knife marks, checking both sides of each end to be sure that the tenons were centered. I wanted to make the cheek cuts quickly, but I didn't want to go too far.

I cut the edge cheeks of the tenons with a dovetail saw, and used a jigsaw to remove the waste between the two tenons. With the end of each shelf housed in the dado these cuts didn't need to be pretty; I only needed to get material out of the way.

Before starting the fitting process, I took a chisel and chamfered the inside edge of each mortise, and with a piece of sandpaper I broke the sharp edge of each tenon to prevent damage to the outside of the mortises during fitting.

With a soft pencil, I made a series of hatch marks on the tenon cheeks and eased them into place. When I met resistance, I removed the shelf and examined the marks. The tight spots showed as smears in the pencil lines and I used a float to reduce the thickness until I had a good fit.

### A Further Complication

Clearly in the grips of an obsessive-compulsive exposed-joinery episode, I laid out each tenon end for a pair of wedges. Unable to leave well enough alone, I decided it would look nice to set the wedges on a slight angle, making dovetail-like shapes in the end of each tenon.

I marked the distance to the edge of each cut on the ends of the tenons with a combination square, then marked the angles with a bevel gauge and knife. The slots for the wedges are at a compound angle, but I only fussed

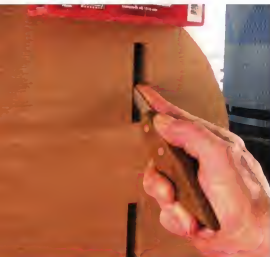

**Marked in place.** The tenons are marked directly from the mortises, ensuring that the locations match.



**Shoulders first.** A shallow rabbet is cut on each side of the shelves to start the making of the tenons.



**Ends second.** The ends of the tenons are cut by hand, then the waste in between is removed.



**Test, don't guess.** Pencil hatch marks on the tenons will smear reveal tight spots within the joints during test fitting.



**A little off the top.** The pencil lines smear where material needs to be removed. A plane-maker's float gives good control and leaves a smooth surface.



**How it ought to be.** The ends can be a bit loose because the wedges will expand the tenons.

about the start of each cut. Using a dovetail saw, I cut the vertical angles by eye.

This meant that the wedges also had to be a complex shape. I began by cutting simple wedges from a piece of purpleheart, about 1" thick, 8" wide and 1 1/2" long. I set the miter gauge on the band saw to 3° and made the wedges by making a cut, flipping the wood over and making a second cut.

I put each wedge in place, trimmed off the end with a saw, then pared the edges with a chisel to match the tenon cheeks. To keep the wedges organized, after fitting a group I stuck them in order on a strip of blue painter's tape, then stuck the tape to the face of each shelf. On final assembly, each group of wedges would be where they belonged.

For assembly, I used liquid hide glue to allow plenty of open time to put the joints together and set the wedges in place. After clamping the assembly, I brushed glue in each slot then drove the wedges in with a hammer. While the glue was drying, I made the back panel.

This panel is straightforward: The rails and stiles join with mortises and tenons that are haunched at the top and bottom extremes to fill the grooves for the panels. The panels are slightly thinner than the frame, and they are raised on both sides. The panel was made about 1/16" too wide to allow for fitting to the case, and the top is trimmed to land in the center of the top shelf.

### Back to Level Ground

When the glue on the case had completely dried, it was time to trim the wedges and exposed tenons down to the surface of the case sides. The first step was to use a flush-cutting saw to remove the ends of the wedges. Then I took a rag soaked with mineral spirits,

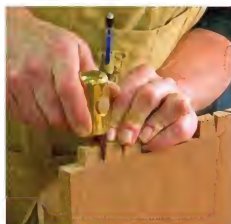

**One size fits all.** In theory, the tapered wedges will fit anywhere. In reality, I fit each one and kept them in order.

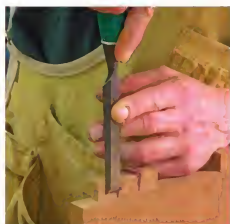

**The easy part.** Each wedge is pared flush with the surrounding tenon. Then they are removed and stuck to a piece of blue painter's tape.

and wet the ends of the tenons.

This saturation makes the tough end-grain fibers easier to trim with a block plane. The final bit of leveling was with a card scraper and when the tenons were flush, I scraped the entire surface of both cabinet sides.

I had set aside a small piece of stock for the backsplash. The grain on this piece arched to match the profile I intended to cut, and with the back in place in the carcass, I trimmed it to final width and length, then marked the curved top edge. After cutting the shape on the band saw, I removed the saw marks with my block plane and shaped the corners with a rasp where the splash meets the case sides.

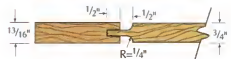

BACK PANEL DETAIL

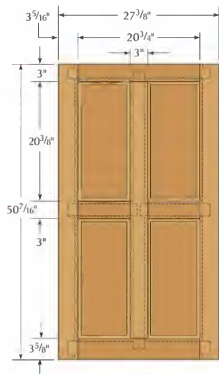

BACK PANEL



**Soak then shave.** After sawing off the wedges, the joints are soaked with paint thinner to make it easier to trim the end grain flush.



**At the same level.** Following the plane, a scraper is used to smooth the exposed tenon ends and the cabinet sides.

### I've Got a Secret

The arched apron below the lowest shelf also was selected with the curve of the grain centered on the cut-out shape. The apron attaches to the cabinet in an unusual way. It actually is the front of a hidden drawer.

The apron is  $\frac{1}{16}$ " shorter than the distance between the two sides of the cabinet, and the  $\frac{5}{8}$ "-thick maple drawer sides are  $1\frac{3}{4}$ " wide and  $10\frac{1}{4}$ " long. The sides join the drawer front with half-blind dovetails, and are set in from the ends about  $\frac{1}{8}$ " on each side. A  $\frac{3}{4}$ "-wide,  $\frac{1}{8}$ "-deep groove was cut in the outer face of each drawer side after the drawer was assembled to hang the drawer on runners.

The drawer runners are strips of maple,  $\frac{3}{4}$ " wide x  $\frac{1}{4}$ " thick, held to the cabinet sides with screws. The reason for setting the drawer sides in was to leave the smallest possible gap between the ends of the drawer front and

the cabinet sides, and to make the runners a substantial thickness.

A small rabbeted lip is left on the end grain of the drawer front, so that any trimming needed to fit the front would be on this small edge. I'd seen a similar detail on an original drawer, and was curious to see if it would be as easy to trim and fit as it first appeared. The final fitting was indeed easier, but this complicated the drawer construction.

I cut the dovetail joints at the front and made the sockets between the pins  $\frac{1}{8}$ " deeper than the thickness of the drawer sides. After fitting the pieces, I took them apart, and cut the rabbets on the ends of the drawer front at the table saw. When I was satisfied with the joints at the front of the drawer, I cut the drawer back to length, then cut the through-dovetails at the rear of the drawer's sides.

Setting the sides of the drawer in from the

ends of the drawer front posed a problem for letting in the groove for the drawer runners. I used a small router with a fence to cut the grooves, but had to temporarily attach thin pieces of scrap on each side of the groove location to keep the base of the router above the end of the drawer front's lip.

After cutting the grooves, I carefully measured back 1" from the inside edge of the rabbet on each side. The fence on the router left the grooves short of this, so I used a chisel to extend the groove to this line, squaring up the end of the groove in the process. It's important that the grooves end at the same point, so that the ends of the runners can act as drawer stops.

I cut the maple runners and fit them to the width of the grooves in the drawer sides. Gravity will keep the top edge of the groove in contact with the runner, so the runner can be sized to slide easily. I left a margin of  $\frac{1}{32}$ " so that the drawer won't bind if the runner swells in width.

After fitting the width, I planed the faces of the runners until the combined width of the drawer and runners with both runners in place was  $\frac{1}{16}$ " less than the inside of the cabinet. There needs to be some room to allow for easy movement of the drawer, but not so much as to make the drawer sloppy.

The drawer bottom is  $\frac{1}{2}$ " thick, and slides into  $\frac{1}{4}$ "-wide,  $\frac{1}{4}$ "-deep grooves in the insides of the drawer sides and front. I used the same setup on the router table for raising the back panels to form the tongue on three edges of the drawer bottom. The back of the drawer is  $\frac{1}{2}$ " narrower than the sides to allow the bottom to slide in after the drawer



**No one will ever know.** Located below the shelf and  $\frac{1}{2}$ " back from the front edge, the drawer appears to be a fixed apron.



**Now you see it.** The rabbet in the end of the drawer front provides clearance for the sides, while allowing a narrow margin to be trimmed easily.

is assembled. A couple screws in elongated holes secure the thick back edge of the bottom to the drawer back and allow for seasonal wood movement.

With the drawer completely assembled, I measured in from the front of the case  $2\frac{7}{16}$ " (the  $\frac{13}{16}$ " thickness of the drawer front, plus the 1" distance from the back of the front to the end of the groove in the side, plus the  $\frac{1}{2}$ " set-back of the drawer front from the front of the case).

I measured down from the bottom of the lowest shelf and drew a line parallel to the shelf to locate the runner. With the drawer front  $\frac{1}{2}$ " behind the edge of the shelf, the top of the drawer front can't be seen when it is closed, so I left a  $\frac{1}{16}$ " gap so the drawer wouldn't scrape the shelf on its way in and out. When I had the positions of the runners located, I screwed them to the inside of the case with #6 x  $\frac{3}{8}$ " flathead screws.

### Easy Elbow Grease Finish

Because I had planed and scraped all the large flat surfaces before assembly, there wasn't much to be done to get ready for finishing the bookcase. I planed the front edges of the fixed shelves flush to the cabinet sides, cham-



**Hidden away.** The hidden drawer rides on wooden slides attached to the carcass. The end of the groove will act as a stop for the runners, and needs to end in the right spot.

fered all of the edges slightly with a block plane, and gave everything a light sanding with #240 grit.

The first coat of finish was Watco Light Walnut Danish Oil. I saturated the surface, wet-sanded it with a nylon abrasive pad, kept the surface wet for about 45 minutes, then

wiped off the excess. This was followed by two coats a day of Waterlox for three days. After allowing the finish to cure for a couple days, I wet-sanded it with Watco Satin Wax and #400 grit wet/dry paper, leaving a nice sheen and a surface that is pleasant to the touch.

The joinery, details and finish on this bookcase are more than what is needed to store some books, but that really wasn't the purpose in making it. The idea was to leave something behind that demonstrates what a bit of extra effort looks like. It makes me look like a competent craftsman. Now to fill it with some books that might make me look intelligent, as well. **PW**

*Bob is senior editor of this magazine and author of several books about furniture of the Arts & Crafts movement. Information on his books is available at his web site: [craftsmanglans.com](http://craftsmanglans.com).*



**Sliding home.** The drawer bottom slides past the drawer back and into grooves in the sides and front. Screws in elongated holes will hold the bottom to the back and allow the bottom to shrink or swell.



**Simple enough.** Maple runners below the bottom shelf support and guide the hidden drawer.

# Folding Campaign Table

BY MARIO RODRIGUEZ



Reproducing  
knock-down  
furniture from  
two centuries ago.

**W**hen on campaign, during the 18th and 19th centuries, British military officers frequently traveled with portable furniture pieces. These durable and compact pieces were characterized by their simple design and various ingenious (hardware) mechanisms that allowed the furniture to be quickly and easily assembled for use or dismantled for transport. A butler's tray-on-stand is typical of campaign furniture and might have been used by officers as a small desk or side table.

---

*A gentleman's table. This folding table has details to stretch your skills using a minimal amount of material.*





*Traveling in style. Elegant details and fine hardwood are hallmarks of campaign furniture, originally used by British military officers.*

Today this piece provides practical utility and versatility in any home. I've used one in my home office to park my dictionary and reference materials, and one in the kitchen to hold cooking supplies. Now I have one by my front door, providing a convenient perch for keys, cell phones and mail. This sturdy tray with a three-part gallery is supported by a folding scissor-leg stand and takes about half a minute to set up. When knocked down, the pieces can be tucked out of the way into any corner or closet.

### Elegant Details in a Compact Form

This is an elegant piece of furniture suitable for almost any interior setting. Meticulously crafted examples, featuring dovetails and turned legs, often fetch top dollar in trendy antique shops and furniture auctions.

The tray bottom is a frame-and-flat-panel construction. The frame, joined by multiple stub-tenons, supports four solid-wood panels. The edges of the tray bottom are eased with a thumbnail profile around the perimeter.

The open front gallery has through-dovetails with a mitered shoulder, an elegant doubled reeded edge, and integral cut-out handholds. Once assembled, the gallery is attached to the tray with screws, counter-sunk from the bottom. The gallery serves to contain items set upon the frame and provide convenient handholds.

The scissor base is made of two frames, pinned at their centers. When open and upright, the stand easily supports the tray. When closed, it folds nearly flat.

In addition to straps (attached to the top rail of each frame) that span the erect stand, there are two retaining support cleats, screwed to the bottom of the tray that prevent the stand from collapsing under any weight.

The tray-on-stand can be constructed of any hardwood, but mahogany is my favorite. This versatile and readily available tropical

hardwood yields clean joints and crisp dovetails, turns easily on the lathe, finishes beautifully and develops a rich patina over time.

### Grooves All Around

Mill and thickness the stock for the frame and panels to  $\frac{9}{16}$ " , then rip the frame stock to 2" . Next, mark out a  $\frac{1}{4}$ " groove, centered on the  $\frac{9}{16}$ " thickness of the frame stock. To achieve a perfectly centered groove, I work carefully from my layout lines and cut a  $\frac{1}{8}$ " groove down the length of each piece, then flip it over and repeat the operation. Remember: Plow only one edge of the outer frame members and both edges of the interior (medial) rails.

After cutting the frame parts to length, set the table saw to cut the shoulders on the stub tenons. Use a piece of scrap marked out for the groove and set the blade height to it. For the length of the tenon, measure the depth of the groove with a gauge and set the blade from the fence to that dimension.

When the shoulders are cut, set the saw to cut the cheeks of the stub tenons. Because the tenon is short, you can safely support the piece on end and against the fence. These two

cuts, carefully set out, should yield an attractive and snug joint.

### Half-lap and Panels

Lay out the intersection of the two pieces with a marking knife. Set two stops on a crosscut gauge to the width of the 2" rails and then set the height of the blade just shy of half the thickness. Make multiple cuts on each piece with a combination blade. Later, clean up the cuts with a shoulder plane. Make sure the intersecting pieces are flush when assembled.

In order to achieve a tight fit at the intersection of the medial rails, make the half-lap cuts slightly narrower than the width of the stock, then plane the edges to precisely fit into the half-lap cuts.

Dry-fit the frame with the intersecting medial rails in place and check your joints for a tight and flush fit. Measure each void in the frame, adding an extra  $\frac{3}{4}$ " to the length and width of each panel. This extra material will eventually form the tongue that holds the panels in the frame.

After cutting the panels to size, mill the tongue on all four edges of each panel. If any of



*Two stops set the width. The half-lap joint is formed by repeated passes over the table saw blade.*



**Cut close and fit by hand.** Each half should measure slightly less than half the thickness of the stock off the table saw. Final cuts with a shoulder plane finish the joint.



**Template in a flash.** Working from your drawing, make up dovetail templates from flashing material.

the panels don't fit easily into the frame, use a shoulder plane to trim the tongue. Dry fit the tray with the panels, checking the assembly for a tight and neat fit.

Now select the best side of each panel for the top of the tray. On the show side of each panel, cut a small reveal ( $1/16$ ") to disguise minor wood movement and provide an attractive accent to the tray.

When gluing up the tray bottom, start with the intersecting medial rails, add the panels, then the short stiles, and finally the long stiles. Make sure all the joints are tight, then with a damp rag, remove any excess glue at the joints or in the reveals that surround the panels.

When the glued-up frame is dry, the thumbnail profile can be moulded on the edge. The safest and most efficient way to perform this operation is on the router table. If you don't



**Dovetails with a difference.** The top pin and tail are mitered, allowing the reed moulding to flow around the corner.



**Wet down the joint.** This will simulate the slight swelling that takes place when you glue up, revealing how tight your dovetails really are.

have a thumbnail router bit, you can use a  $3/4$ " bullnose bit. Make sure to center the material on the bit for a balanced profile.

### The Gallery Corners

The three-part gallery is joined at the corners with through-dovetails with a mitered

shoulder. This detail adds strength and an elegant touch. I recommend cutting the tricky dovetails before going to the trouble of shaping and reeding the edges and cutting out the handholds. That way if you're dissatisfied with the dovetails your investment, in terms of time, is minimized.

When laying out dovetails, I work out the angle, dimensions and spacing of the dovetails on thin sheet metal (aluminum flashing). I find it gives me a chance to examine and change the layout before marking out the workpieces. Using templates also allows me to mark out both the front and back of both workpieces easily and accurately.

Once you complete the layout on the metal (using either a sharp pencil or marking knife), cut the outline of the tails with stationary scissors, down to the template baseline. The waste is then removed by simply folding it back and forth, at the baseline with needle-nose pliers until it breaks off.

The gallery dovetails have to be mitered because of the reeded edge along the top. These dovetails are much like regular dovetails, except that both the top half pin and tail are mitered. They're not harder to cut, but require an understanding of the unusual joint so you don't cut away essential material by mistake. I would recommend cutting a

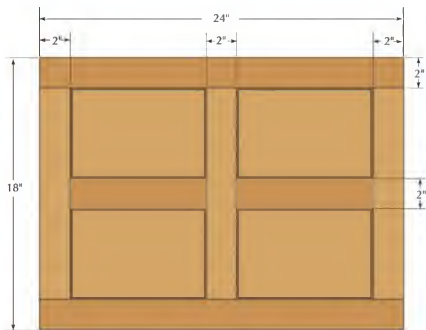

PANEL PLAN



**Along the curve.** A plywood template is used to guide a reeding bit along the serpentine edge of the gallery.



**Shape now, drill later.** Cut the pommel on the ends of the upper and lower sections, then drill out the mortise.

couple practice joints before attempting the real thing. After dry fitting the dovetail joints, carefully pass a fine dovetail saw through the miter to ensure a tight fit.

If you're not confident about your dovetails, you can substitute a simple miter reinforced with decorative brass corners.

### Shaping, Turning and a Clever Joint

Once the dovetails are cut, shape the serpentine edge of the gallery with a plywood template and router. The reeds can be cut with the same template. I only had a three-reed bit, so I "buried" one of the reeds and only cut two on the gallery edge.

Finally, rough out the handholds with a  $\frac{5}{8}$ " Forstner bit, leaving about  $\frac{1}{8}$ " of waste to remove later using a plywood template and a  $\frac{1}{2}$ "-diameter flush-trim router bit. If you choose, the handhold can be further smoothed with a  $\frac{1}{4}$ "-radius roundover bit. The completed gallery is attached to the tray with #6 x 1" brass flathead screws, neatly countersunk.

The legs measure  $1\frac{1}{4}$ " square by  $36$ ". Depending on the length of your lathe bed or your ability as a turner, you may choose to turn the legs in three segments, rather than in a single piece. There are three advantages to this method:



**Take it for a spin.** A block plane can be used on the lathe to achieve smooth, straight cylinders.



**Square parts, turned tenon.** The leg-to-foot joint should be snug with even shoulders all around.

1. The length of your lathe bed may not accommodate a blank  $36$ " long.
2. Turning a shorter blank will significantly reduce whip and chatter.
3. Turning the pommel (the intersection of the square section to the round portion of the leg) separately may yield a cleaner joint.

Here's how to turn the legs in three sections. After mounting the center portion of the leg between centers, use a narrow parting tool to establish the shoulders of the center

square. Then rough out the round sections on each side of the square. I like to use a shallow gouge, which I find easier to use than a skew, to round and smooth the cylinders. A similar gouge is sold by [toolsforworkingwood.com](http://toolsforworkingwood.com) as the 3-in-1. To remove any dips along the cylinder's length, use a block plane. Note: The upper cylinder tapers from  $1$ " to  $\frac{7}{8}$ ".

Once the cylinders are done, I carefully round the shoulders of the center square with a skew. The goal should be to achieve a smooth, crisp pommel. This may take some practice on scrap before attempting the cut on an actual workpiece.

Turn a  $\frac{5}{8}$ " tenon on each end of the center section to fit into the top and bottom squares. I use an open-end wrench and a parting tool to size the tenon for a tight fit.

The centers of the top and bottom squares should be carefully marked out before turning the shoulders on the lathe. Make these blocks longer than called for. This extra material will provide a margin for several practice cuts. Once you're satisfied with the results, you can cut off the excess and drill the mortise hole.

After fitting all the parts together, check the alignment of the square parts by laying the legs on a flat surface. Then mark each joint so everything goes back together in the same position during glue-up.

### Making the Connections

For a  $29$ " finished tray height, the legs should be  $36$ " long. Carefully mark out the leg angle

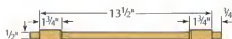

RAIL

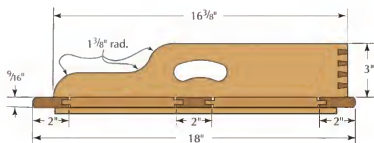

SECTION



LEG



**Clamp in position.** Leg assemblies are clamped to the bench before webbing is tacked to the upper rails to hold the legs in the open position.

cuts to avoid any mistakes. Then following the layout lines, cut the ends just shy of 39°.

Each frame has a square and a turned rail. The square rail is at the top, hidden by the tray. The lower rail is turned to a pattern similar to the legs. Both have 1/2"-diameter x 3/4"-long lathe-turned tenons.

The top (square) rails should be oriented so one side is parallel with the floor (to provide a flat mating surface for the underside of the tray) and the rails should be offset 1/8" below the top of the legs to allow for the canvas strapping.

Check the lengths of the bottom and top rails against each other. The narrower frame

should fit easily into the wider one, with about 1/8" to 3/16" of play. Glue up the narrower frame first, then the wider frame.

Assemble the frames with #8 x 2 1/2" brass screws. Use washers between the frames to prevent the frames from sticking or accidentally rubbing together. After the frames are assembled, attach canvas or nylon strapping to the top rails. These straps will support the stand in an open position at the correct height.

Here's how: Open the assembled stand, setting the feet flush upon a flat surface. Then clamp a plywood straightedge to the feet (this will maintain the open frame in the correct position and height). Wrap a length of strapping around the top rails and nail it tight with small brass brads.

The cleats are cut to fit on the underside of the tray and between the legs. The straps hold the stand open and at the proper height. The cleats support any weight placed on the tray. After cutting the cleats to length, drill and counterbore holes for #6 x 3/4" brass screws.

After sanding the tray and stand with #220-grit paper, I finished the wood with three sprayed-on coats of lacquer, rubbing out the first two coats with a burgundy abrasive pad. Before the last coat, I applied a glaze of McCloskey's Glaze Coat and black Japan pigment. While the glaze was still wet, I rubbed it into the grain and corners. This darkened the color slightly and gave the tray the appearance of an antique. **PW**

*Mario has been a woodworker, author and teacher for more than 30 years, and is the resident instructor at the Philadelphia Furniture Workshop. Information on available classes can be found at [philadelphiafurnitureworkshop.com](http://philadelphiafurnitureworkshop.com) or by calling 215-849-5174.*

## Supplies

**Whitechapel Ltd.**  
800-468-5534 or  
[whitechapel-ltd.com](http://whitechapel-ltd.com)

2 ■ decorative brass corners  
#277CS2P, \$2.99 each

**Tools for Working Wood**  
800-426-4613 or  
[toolsforworkingwood.com](http://toolsforworkingwood.com)

1 ■ 3-in-1 gouge  
#IT-MARIO125r, \$131.95

*Prices correct at time of publication.*



## Folding Campaign Table

NO.	ITEM	DIMENSIONS (INCHES)			MATERIAL	COMMENTS
		T	W	L		
4	Legs	1 1/4	1 1/4	36	Mahogany	
2	Long stretchers	7/8	7/8	15	Mahogany	One turned, one square 3/4" tenon both ends
2	Short stretchers	7/8	7/8	12 1/4	Mahogany	One turned, one square 3/4" tenon both ends
4	Panels	9/16	6 3/4	9 3/4	Mahogany	Grain runs along length
2	Stiles	9/16	2	24	Mahogany	
1	Medial stile	9/16	2	20 3/4	Mahogany	Mill for half-lap, 3/8" tenon both ends
3	Rails	9/16	2	14 3/4	Mahogany	1 milled for half-lap, 3/8" tenon both ends
2	Gallery sides	1/2	3	16 3/8	Mahogany	
1	Gallery back	1/2	3	23 1/4	Mahogany	
2	Cleats	5/8	3/4	*	Mahogany	* Cut to fit assembled leg frames

# Thickness Planers

by Marc Adams

When I started woodworking, owning a planer was just a dream. They were big, expensive and power-hungry machines that were not well suited for the small shop or hobbyist market. At the time I knew very few people who owned one. Today, thanks to the import market, planers have become affordable machines. Nearly every small woodworking shop has one and today even contractors can tote lightweight portable planers to the job site. I often poll my students to ask how many people own planers, and nearly 100 percent raise their hands.

The planer is the most unassuming machine in the shop. Simply set the depth of cut and the machine does all the rest. It is the only machine in the family of common stationary power machines that is automatic – it does all the work. All you have to do is put the

**A proper planer.** *Though planers seem simple and safe, there are some serious operational and safety issues to consider. Follow these rules and your work will be better and you won't get hurt.*



PHOTOS BY AL PARRISH

## A Better Way to Work • Part 6

# WOODWORKING Essentials

wood in and let the machine take over. The cutterhead and all other moving parts are well guarded, there is plenty of control surface for safe operation and the machine limitations are well defined. So what would be the reason to discuss safety of such a simple and unpretentious machine? I believe that if an accident were to occur on a planer, it quite possibly would be the worst accident that can happen on any wood-working machine in the shop. Think of it: The planer pulls the wood into the cutterhead with unforgiving power. Imagine if it were your clothing or — heaven forbid — your hand. It would quickly become disastrous.

Because the machine does all the work, it is easy for the user to day-dream or lose focus, especially when running lots of lumber. And most often accidents occur because the operator isn't paying attention. Because the cutterhead, infeed and outfeed rollers do not have a quick braking system, the machine would still continue to run and pull towards the cutterhead — even as it slows down after the stop button has been engaged. Not to mention that planers generate kickback, have tremendous pinch points, make terrible noise and generate a huge amount of dust. All of a sudden, this unassuming machine becomes one of great concern.

The basic function of the thickness planer is to smooth rough stock or to reduce the thickness of any piece of wood. The planer will not correct or straighten warped stock because the pressure of the infeed roller will press the warp out of the board as it passes into the cutterhead. As soon as the board passes beyond the outfeed roller, the board will resume its warped shape.

Most planers cut from the top and are built rugged enough to take the shock and stress of cutting wide, rough lumber. The size of the planer is determined by the knives or the widest stock it can surface.

Most of today's small shop planers have a cutting width of between 12" to 20" and can handle wood up to 6" thick. Depending on the size of the motor and the type of stock being machined, it is recommended that a typical pass be less than 1/8" in depth of cut, with the average cut being around

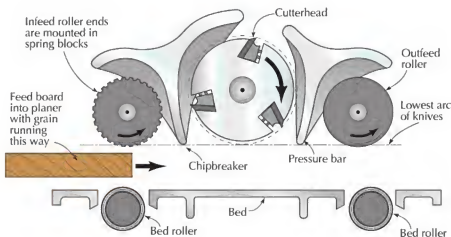

THE INNER WORKINGS

1/16". Some machines have limiting bars that restrict the depth of cut from pass to pass. But there are those monster machines that can take off up to 1/2" depth of cut at each pass. There are also planers that are designed to do moulding operations, straight-line ripping and even planers that convert into jointers. No matter what kind of planer you have, the rules of safety for the machine will be the same.

Because the planer does all the work when it comes to moving and cutting the stock, the best way to understand the safe application of the machine is to understand its moving parts.

We sometimes take for granted the action of motion that takes place with a planer. From the infeed side the motion is to push and from the outfeed side the motion is to pull. Both infeed and outfeed rollers are under spring tension. This tension must be sufficient enough to feed the stock uniformly through the machine without slipping, while at the same time not be so tight that it causes damage to the board. Believe it or not there is quite a difference between the action, setting and design of these two rollers, but they both still have a high degree of pinching force.

#### The Infeed Roller

The function of the infeed roller is to push the material into the machine and it is the workhorse of the planer. It is spring-loaded, which helps hold the board against the control surface of the bed and relieves kicking forces. Infeed

rollers are usually spirally corrugated to give the roller grip and add to the muscle of the pushing motion. It is important that when sending multiple boards through at the same time that they be very close to the same thickness. On high-dollar planers the infeed corrugated rollers are also segmented to allow boards of different thicknesses to be sent through at the same time. These segmented rollers can accommodate wood variances of up to 1/4".

To provide proper drive, the infeed roller should be set so that the bottom of its arc is just below the arc of the cutterhead knives. Definitely read the owner's manual to get the exact recommended setting, but it will be around 1/32". Remember: Both the infeed and outfeed rollers have to be parallel with both the bed of the machine and the cutterhead knives. Otherwise your work will have a tendency to skew one way or the other when it's feeding.

#### Outfeed Roller

The outfeed roller continues to feed (pull) the wood through the machine after it leaves the infeed roller. Outfeed rollers are smooth and some are even rubber coated to prevent damage to the surface of the wood. Because the outfeed roller is smooth it does not have nearly the muscle of the infeed roller. If you find that you have to help pull that last bit of your board from the planer, don't get frustrated. Just remember this side of the machine is not as powerful as the front of the machine. If your

boards are really having problems being pulled from the machine, either wax the bed or adjust the outfeed roller.

The correct free position setting of the outfeed roller is  $\frac{1}{32}$ " below the arc of the cutterhead knives. Verify this by reading the owner's manual.

### Anti-kickback Fingers

Not all planers have anti-kickback fingers, but they are an important safety feature. They are out of the way and are adjusted at the factory. They operate by gravity and should be inspected frequently to make sure they are free of pitch and gum and that they move independently of each other.

### Chipbreaker

Between the infeed roller and the cutterhead is the chipbreaker. The chipbreaker serves several important functions including: Breaking chips into smaller pieces, to help avoid splintering out of the wood, to help keep thinner stock from bouncing and to direct the flow of the chips out of the machine to the dust collector.

The edge of the chipbreaker is set fairly close to the knives of the cutterhead and can be adjusted up and down. Chipbreakers are usually spring-tensioned or free-floating. If the chipbreaker is set too low, it may prevent stock from feeding into the machine. If

it is set too high, snipe could occur on either end of the board.

### The Pressure Bar

High-end planers have pressure bars located just behind the cutterhead and situated fairly close to the knives, just like the chipbreaker. The purpose of a pressure bar is to hold the material down after it passes under the cutterhead until the stock reaches the outfeed roller. It helps eliminate chatter marks.

Because most planing problems can be related to the pressure bar, some manufacturers choose not to put them on their machines. Instead they move the outfeed roller a little closer to the cutterhead. If your planer has a pressure bar, it must be set at the exact depth as the arc of the cutterhead knives. If it is too high, you will get a snipe in the last bit of the board. If it is too low, the stock will not feed.

### Bed Rollers

Many planers have bed rollers. They reduce the friction of the stock on the bed as it feeds through the machine. On high-dollar planers the bed rollers can be quickly adjusted with a lever. On most middle-of-the-line planers these rollers are set at the factory. They can be adjusted, but it takes work. The rollers are usually set  $\frac{1}{32}$ " above the bed height at the factory.

Bed rollers can be both good and bad. If your lumber is thick, rough and twisted, the extra rollers help move the stock through the machine. However, as the stock gets thinner and is able to "flex," the bed rollers become a major problem. Here's why. If you look at the drawing on page 52, it shows the typical setting of the bed rollers. They are slightly higher than the bed. Remember that the infeed and outfeed rollers are spring-tensioned and have a tendency to "pinch" the wood to the table. It just so happens that the infeed and outfeed rollers are pretty close to the same location of the bed rollers. That means that as the stock is "pinched" between the top and bottom rollers, the stock that is directly under the cutterhead is unsupported. As each knife of the cutterhead strikes the wood it causes the thin stock to "bounce." This can cause some wood to shatter. This is why I always use a sub-table when planing thin stock.

### Feed-speed Control

The cutterhead normally operates at a fixed rate of about 3,000 to 3,600 rpm, but most planers have a quick control for changing the feed rate from rough to finish surfacing. The feed rate is affected by the speed of the infeed and outfeed rollers. The feed rate should be varied with the width of stock, the



**Flip after each pass.** It's good practice to remove material from both faces of your work (once both faces are planed flat). To keep your board's grain direction oriented correctly, flip each board end-for-end after each pass.



**How not to get pinched.** The bed of the planer should be a serious source of concern – it's an easy place to get pinched. The wrong way to feed the work (left) is to hold the board from underneath. The correct way (right) is to hold the board by its edges whenever possible.

kind of wood and the desired quality of the surface of the stock after planing. Wider boards and harder woods should be fed at a slow speed, and narrower pieces of softer wood at a higher rate. Because the infeed and outfeed rollers are typically powered by the same motor as the cutterhead, when the machine is under exceptional load the rollers usually slow the feed rate as well.

### Be Aware of Pinch Points

For the most part, pinch points on the planer are benign until the machine is turned on. Once the machine is on, these points become alive – regardless of what's in its way. Remember: The machine can't think but you can.

Other than the obvious pinch points such as belts, pulleys, chains and cranks, the infeed and outfeed rollers

present a special kind of pinch point. Remember these rollers are spring-tensioned and have a tendency to force wood to the bed. If your hands are caught under the board when the infeed roller engages the wood, they will be smashed. I make it a habit to try to hold my boards from the top side as I load them onto the bed of the planer instead of the natural way of holding from beneath. At times when planing rough boards the tendency will be to wear leather gloves to protect your hands from the rough-sawn edges. I hate splinters as much as anyone, but under no circumstances would I ever wear gloves when running a planer. Never let your fingers slip into any knot holes, grooves or any other irregularities on the board.

The beds on planers never seem to be long enough, so in an effort to extend the beds for more support some manufacturers include an extension roller that can be added to both the infeed and outfeed side of the bed. These extension rollers are the most dangerous devices I have ever seen – especially on the outfeed side of the bed. Imagine that your mind drifts and as you reach to the outfeed side to grab the board, your hand gets between the extension roller and the wood. Once the board pinches your hand, it will continue to feed and will cause a serious injury. If you have these rollers I suggest you add a sub-table board that is long enough to cover the danger of this overlooked pinch point.

Remember the 3<sup>rd</sup> rule from the

**The danger zone.** Planers can kick back at you – and quite violently. Never stand directly in front of the machine while operating it. Stand to the side. The tape on my shop floor is a good reminder of where not to stand.





previous articles on safety? On the planer that means that your hands should be at least 3" from the front or back opening of the machine along with any guards, shields, pulleys or anything that can grab or pull you in.

### Planer Kickback

Kickback on a planer can occur for many reasons. If wood does kickback it will more than likely be thrown toward the infeed side. However, if a piece of wood shatters in the process of cutting creating a kickback, these bits of shrapnel could ricochet on the inside of the machine and fly out the either the front or back of the machine. This is why rule number one is to never stand behind your work. Always stand to one side of the machine on both the infeed and outfeed side. Never stoop down to watch a board being surfaced. Never stack boards on top of one another and run them both through the machine. Kickbacks most likely will occur because of one of the following reasons:

- **Knots.** Knots are not always solid. Loose knots can be pulled or knocked loose from the board. Once they are free inside the machine, they can easily come in contact with the rotating knives and be thrown out.

- **Short stock.** There are definite rules about running short stock through the planer. Never run stock that is shorter in length than the distance from the infeed roller to outfeed roller. This is why the 12" rule exists. If your stock is less than 12" long, you should take a moment of pause and determine if that piece is too short for your machine. In the case of the planer the rule is the shortest board that the machine can handle should be 2" longer than the distance between the infeed and outfeed rollers. That way stock will always be supported by one of the feed rollers. If the stock is shorter than that distance, it can get trapped between the two rollers with no support at the point of action, creating a kickback. When surfacing several pieces of short stock, (short meaning stock that it is still longer than the distance of the infeed and outfeed roller plus 2") they should be fed by butting the ends. These butted pieces will help

push each other out of the machine and they will be less likely to stick under the chipbreaker or pressure bar.

- **Wood that shatters.** Thin stock can easily shatter under the force of the rotating knives. The grain direction and character of the grain, such as curly, swirly or burl wood, or wood with serious defects, can shatter while being planed. If the chipbreaker is set too high, the stock can tip up into the cutterhead causing the stock to split or tear unevenly. Forcing the feed or taking too much of a cut can cause the wood to shatter as well.

- **Nails or debris.** Always check the wood before planing to make sure that it is not embedded with foreign material. Even dirt or small bits of sand can nick the knives, which in turn could grab the wood awkwardly and possibly throw it out of the machine. Be especially careful with old lumber that may have hidden nails or debris. Foreign objects such as old nails, bolts or staples can cause the knives to break or be pulled out and be thrown from the machine. Glue lines or wood that has an existing finish on it could cause undue wear on the knives, and dull knives can cause potential kick-off forces.

### Distorted Stock

Wood that is warped, cupped, twisted or bowed could cause inconsistent contact with the blades, which in

turn could cause kickback. It is best to joint these boards on one face before planing. Serious stock flaws cannot be removed by the planer alone. Never feed two or more boards through the planer at the same time that are not consistent in thickness. Most consumer planers do not have sectional infeed rollers and sectional chipbreakers to accommodate wood of varying thicknesses. When surfacing a number of pieces to a given thickness, it is a good idea to run the thickest pieces first. Once these thicker boards become equal in thickness to the remaining boards, you can then run them all together at the same setting.

### Limitations

Planers do have obvious limitations. They are limited by the length of the knives and the opening depth of the machine. You will be limited by how long a board you can send through the machine by the walls in your shop. In my first shop, I situated my planer in front of the garage door so that all I had to do was open the door to send long stock through the machine. If your planer is portable then length will not be an issue. We have already discussed that the shortest length of board you can send through your planer is based on the distance between the infeed and outfeed roller plus 2".

How thin stock you can plane will



**The planer train.** When planing short stock, you should always butt the ends of the boards against one another as you feed them into the machine. This will reduce kickback and snipe.



**Pushing the limits of thinness.** Your planer has limits as to how thin it will plane your work. If you need thinner stock, you need to use a sub-table board to get your work thinner. Note that this can shatter your work.

be determined by two factors – using a sub-table board or not using a sub-table board. Most planers are designed so that you cannot lower the blades into the bed. If you use a sub-table, you can plane your wood all the way to oblivion. Most often you will find that as your stock gets thinner, it will have a tendency to shatter, which can be very dangerous. At some point, planing very thin stock should give way to a better machine such as an abrasive planer or drum sander. It might help to send smaller stock through at a slight skew angle to provide a smoother feed and to create a shearing cutting action.

Planers are also limited on how much material can be removed per pass. The thickness of the cut is usually determined by the width of the stock, the hardness of the wood, the feed rate and the finish desired. Although planer manufacturers recommend that passes be limited to less than  $1/8"$ ,  $1/16"$  is probably the most common pass setting.

### Clearing Jams

Periodically, wood will have a tendency to jam somewhere between the infeed and outfeed rollers. Jams can occur because of many reasons including: improper machine settings, wood that is inconsistent in thickness or width, knots or debris, infeed or outfeed roller

malfunctions or distorted stock. When a jam occurs the safe thing to do is to stop the planer, stand to the side and wait for all moving parts to come to a complete stop. If the jam requires that you stick your hand into the machine make sure you unplug it first. Once the jam has been cleared, evaluate and correct the cause, then resume action.

If the board is thicker at one end than the other and jams during feeding, you do not need to shut off the machine. You can slowly crank open the adjustment wheel until the board resumes feeding. The reason this situation will not create kickback is because the infeed and outfeed rollers are totally engaged in the wood. Lightly lowering the bed position will relieve the bind that created the jam. However, it is always better to stop the machine, make the adjustments, then start it up again.

### Dust Collection

Planers produce a large amount of dust, chips and fine shavings. It is definitely recommended that an adequate dust-collection system be used. Be aware that chips from the planer are passed at a high rate of speed and in the right conditions can cause a static charge. Make sure to properly ground your planer's dust collection system. **PW**

Marc is the founder and owner of the Marc Adams School of Woodworking, the largest woodworking school in North America. For more information on the school and its excellent curriculum, visit [marcadams.com](http://marcadams.com) or 317-535-4013. You can download a free list of safety rules for planers at our web site at [popularwoodworking.com/aug08](http://popularwoodworking.com/aug08).

## Work with More Accuracy (and Safety) in your Woodshop

The best way to use your machines is rarely explained in the manual. Find out how to operate machines to get accurate results without sacrificing safety.

### • Part 6 Thickness Planers

Powered planers seem like safe machines until you start testing their limits.



## IN FUTURE ISSUES

### • Part 7 Table Saws

The fundamental skills to get good (and safe) results with one of the most important woodworking machines.



## IN PAST ISSUES

### • Part 1 Learn the Skills to be Safe

The groundwork for a lifetime of accurate woodworking is to understand your tools.



### • Part 2 Practical Safety Devices

Choose the right guards, push sticks and hold-downs to work safely.



### • Part 3 Power Jointers

Most people use their jointers wrong, resulting in warped stock and unsafe operations.



### • Part 4 Miter Saws

Stock miter saws are neither accurate or safe. Here's how to fix both problems.



### • Part 5 Band Saws

Band saws are safe if used correctly; however it's easy to step over the line and get bit.



## Online EXTRAS

For a printable list of planer safety tips, visit: [popularwoodworking.com/aug08](http://popularwoodworking.com/aug08)

# FEDERAL FURNITURE

BY ROB MILLARD

Years ago I discovered Federal furniture and knew that with beautiful veneer, superb inlay and simple carving, this would be my furniture period of choice.



*A showcase for veneer. An upsurge in veneer usage presented more options for woodworkers. This candlestand's top would be all-but-impossible to create out of solid hardwood.*

Federal furniture has much to offer woodworkers. In addition to the traditional joinery, there is veneering, inlay (stringing, banding as well as pictorial), reeding, curved work and some carving. Initially it was the rigid symmetry that drew me to the style – followed closely by the lavish use of highly figured woods. (What woodworker doesn't appreciate beautiful wood?)

Of course, the defining features of Federal furniture are the veneers and inlays. Veneers had been a feature of William & Mary furniture, and a limited amount of veneer and inlay work occurred during the Queen Anne and Chippendale periods, but nothing like on the scale seen during the Federal period (1785 - 1810).



**Federal period woodworking.** This shelf clock exhibits many attributes of Federal furniture design. The use of veneer and inlay work (bandings, stringing and a pictorial inlay) signaled a transition from Queen Anne and Chippendale furniture.

### The Attraction of Veneer

The expansion of American trade in the 18th century delivered many exotic and beautiful veneers. Cabinetmakers of the period certainly explored the use of those veneers. Veneers were used with dramatic effect to decorate surfaces in geometric patterns or those surfaces were used as a palette to display highly figured veneers. Often these veneers were outlined with stringing or bandings of multiple contrasting woods.

At first I had only a vague understanding of what veneering was, but the idea of being able to use thin sheets of wood, hide glue and a veneer hammer to produce striking furniture facades fascinated me. Today, that process still has me in its grip; there is nothing like it.

Veneering is actually an easy way to decorate a beautiful piece of furniture because Mother Nature has done the hard part by creating such diverse species and impressive grain patterns. Veneering also allows you to create objects that wouldn't be possible in solid wood – the sunburst pattern on the candlestand shown on the previous page, for example – and work with species not commonly available as thicker lumber.

### Bandings, Paterae and Stringing

Equally interesting are the bandings. These display an astounding level of craftsmanship,

especially when viewed in light of the conditions under which period craftsmen worked. I appreciate the geometry of bandings. It gives me an opportunity to do precise work and apply some creativity in their production,



**Pictures in wood.** Different veneer species and/or dyes, along with sand shading, give this inlay depth and “pop.” Notice the line, engraved lines that define the arrows held in the eagle’s claw.



**Some curves included.** Though often thought of as linear in design, Federal furniture exhibits plenty of curves. This card table design uses an oval veneer inlay accented by twin stringing to highlight the curves.

plus there is the satisfaction of producing what looks to be incredibly detailed works of art.

Like most people, when I first saw the bandings on Federal furniture, I couldn't understand how they were made. I envisioned having to glue many small pieces directly onto a workpiece. In truth they are quite easy to make as a block with individual strips sawn off before being inlaid. It's a toss-up as to whether making bandings or veneering is my favorite aspect of this period.

Rivaling these bandings are the pictorial inlays known as "paterae." Pictorial inlays are a common feature of the Federal style and range from fans to shells and more. Many are incredibly artistic. Standing out among these pictorial inlays are the eagles that adorn many pieces. These are among my favorites, but conch shells are also impressive.



**Not just for straight lines.** This basin stand (above) demonstrates the importance of string inlay. When wrapped around other inlay or used to define edging, stringing focuses your eye and influences the design.



**Only simple carving required.** Most Federal furniture has little figural carving, but the reeding on the legs is one form of carving that's found in abundance.

While not common, some inlays are further enhanced by engraving fine lines and filling those lines with a mixture of lamp black and glue. And, from the standpoint of simplicity of construction yet with a formal appearance, nothing equals the various forms of a sand-shaded fan. I'm continually in awe of the way sand shading adds so much depth and brings these inlays to life.

Second only to veneer in the ease with which it enhances a piece of furniture, is stringing. Stringing is narrow strips of wood, either solid or multiple layers of contrasting species, used to set off various veneered elements, to accentuate the shape of components, or as geometric, decorative ornamentation.

### Federal Has Curve Appeal

Curves abound in Federal furniture, and they run the gamut from the gentle, such as those on a bow-front chest, to the bold, found on sideboards and card tables. Making these curved pieces is certainly a challenge, but the effort is rewarded with a piece of furniture of great visual interest that befits a true craftsman. Here again the veneering plays an important role in these curves, many of which, if made in solid wood, would either be impossible due to the unstable nature of the species, or the grain pattern would take on an unnatural look from the undulating shapes.

Last but not least on the list of features that drew me to Federal furniture is the overall lack of carving – which matched nicely with my lack of carving skills. What carving there is, with few exceptions, is not the fluid foliage

**Up-to-the-minute design.** Antique tall-case clocks bear the name of the maker of the movement, but most clocks are collected by museums for their importance as furniture. The maker of the antique clock that I copied mixed the veneer species and special bandings to make this design a Federal masterpiece.





carving typical of the Chippendale period, but keeps with the geometric nature of Federal furniture. And that also suits me.

Falling loosely in the carving category is the reeding on the legs of late Federal-period pieces. Despite my lack of enthusiasm for carving, I do enjoy reeding a turned leg due to the sense of elegance the finished legs impart.

### From the Beginning

No discussion of this period would be complete without a little of history behind the style. This is another aspect I enjoy, because it combines my interest in history with the woodworking.

The Federal period coincided with the emergence of our Republic, but its origins were in the mid-18th century, with the discovery of ancient Greek and Roman ruins. Interpretations of these discoveries were the rage in all of Europe.

Among the most prolific designers to embrace this new style was Robert Adam who, along with his brother, published "Works in

*Dynamic duo.* Combinations of veneer and stringing were used to enhance projects. Both clock doors are veneered. The lower door is most obvious with a panel set inside the string. But under close scrutiny, the upper door reveals the entire frame is covered with edge banding.

Architecture" in 1773. This book was very influential and signaled the demise of the Rococo style.

This new style, referred to as Neoclassical, was refined even further during the next decade or so and these changes were displayed in the published works of George Hepplewhite (1788) and Thomas Sheraton (1791-94). The influence of these two men was so great that their names now define the style.

Although we had won our independence from England, the country's influence was still pronounced. So naturally, what became popular in England was adopted here – although somewhat later and with our unique interpretation. Americans, with their new-found independence, were drawn to this style not only because of the influence from England, but also the perceived connection between our new republican government and those of the Romans and Greeks.

### A New Wave of Design

American Neoclassical furniture is generally less ornate than its English counterparts and, like the Queen Anne and Chippendale furniture before it, was typically more vertically oriented. The changes were so significant that this new style became known as "Federal," referring to our then-new Federal republic.



*You can't help but notice.* Sideboards, not found in homes prior to the neoclassical period, became the focal points in many dining rooms and these stately pieces included many of the period's woodworking characteristics.

When the Queen Anne style was supplanted by Chippendale designs, the change was minimal and fairly gradual; the types of furniture remained constant and only the surface ornamentation and perhaps the boldness changed. In contrast, the Federal/Neoclassical style changed everything, and quickly. Characterized by symmetry and lightness, Federal furniture must have been a shock when first shown, and even today it looks quite modern, rivaling current studio furniture.

Gone for the most part is carving, and what carving remains is more delicate. The cabriole leg with ball and claw feet that dominated the Chippendale period aren't found on Federal pieces; instead, delicate tapering legs and later, turned and reeded legs dominate the style.

Gone too are the bold mouldings, replaced with more rectilinear shapes. That does not mean complex shapes are not to be found. Indeed, many pieces display an abundance of curves yet are still refined and delicate in appearance. There are pieces of Federal furniture that when stripped of any surface ornamentation, are quite simple and similar in design to Shaker furniture.

In addition to the new style, some new furniture types appeared at the beginning of the Neoclassical period, or became more prevalent. Sideboards, unheard of before this

period, became a focal point of the dining room, and were often imposing pieces with complex curved facades, adorned with a full range of Neoclassical details. The proliferation of worktables reflected the increased influence of women in the home. Card tables certainly existed before the Federal period, but they reached their zenith during this period, with nearly endless variations of shapes and levels of ornamentation.

In the end, the thing I enjoy most about Federal furniture is putting myself in the shoes of the original craftsman and trying to imagine the "how" and "why" of their techniques and designs. They worked without good lighting, having never heard of the band saw, router

(there are times when I wish I hadn't heard of this tool), surface planer or random-orbit sander. My respect for those craftsmen and their furniture only deepens and I find the shoes don't really fit—they are too big. **PW**

---

*Rob builds Federal-style reproductions in a one-car garage shop. Also, he has written for the Journal of the Society of American Period Furniture Makers. Visit his web site at [americanfederalperiod.com](http://americanfederalperiod.com).*

**Skill and expertise.** Details of this desk, originally built by well-known Federal furniture makers John and Thomas Seymour, illustrate the exquisite craftsmanship of the period.



**Slimmer legs.** Cabriole legs (found on many Queen Anne and Chippendale pieces) were cast aside and replaced with delicate, tapered legs at the advent of the Federal period.



#### About the Furniture

All the pieces shown in this article were built and photographed by Rob Millard, the author.

# Making Multiple Through-Mortise

Wedged mortise-and-tenon joints add visual interest to any casework.

BY ROB PORCARO

To join partitions or shelves into solid-wood casework, woodworkers have several options. This basic task of connecting the end-grain edge of one board to the face of a second board can be dispatched with simple nailing, or indulged with precision sliding dovetails. One of the most elegant options is the multiple mortise and tenon.

Woodworkers may shy away from building this joint because it seems complex, even intimidating. The traditional approach to construction involves burying the end of the tenon piece in a fully-housed dado in the mortise piece. I believe this unnecessarily complicates building the joint, leaving almost no margin for error. More important, it creates problems in case construction. I hope to show that add-

ing this joint to your repertoire is doable with much of the same general skill set that you're already using for making dovetails. Better and easier – now that's what I like.

I'll guide you through the construction of a sample joint using two short pieces of  $\frac{3}{4}$ "-thick hardwood about  $5\frac{3}{8}$ " wide. The vertical board in the photo below left will be the tenon piece, which will be joined to the face of the mortise piece.

The key to this method is to start with a "giant tenon" with a narrow shoulder. This offers several advantages over a fully housed dado. First, the shoulder will keep the joint line tight and clean, even as the wood seasonally varies in thickness. Second, you can do final smooth planing of the surfaces after



**The basics.** The vertical board is the tenon piece which will be joined to the face of the mortise piece.



**Giant tenon.** The key is to start with a giant tenon with a narrow shoulder.



# -and-Tenon Joints

you have made a final dry fitting of the joint. Third, it allows you to plane the subtle adjustment of a drawer housing in a case, such as to make the rear of the housing a hint wider than the front. Finally, the shoulder is a handy and reliable registration for shelf or partition length in a case.

## Let's Get to Work

Accurately square up the end of the tenon piece using your preferred method. I use my crosscut sled on the table saw, then make any necessary refinements with a hand plane plus a shooting board. Then I make a  $1/16$ "-deep rabbet using my router table, registering the squared end of the board against the fence. For long boards, such as shelves, use a hand-held router with its fence. Hand tool folks, go ahead and use that rabbet plane. The width (long dimension) of the rabbet should be about  $1/8$ " greater than the thickness of the mortise piece to allow that much extension of the tenons beyond the mortises. The waste will be sawn off as the final step.

Now I use a plastic drafting square, registered against the narrow shoulder, to divide this "giant tenon" into small tenons. In this example, the tenons are  $3/8$ " wide and the members of each pair are separated from each other by  $3/8$ ". The tenons should be marked out to give good proportions, but perfection is not necessary because the mortises will be marked from the actual tenons. For boards more than 9" to 10" wide, consider using three



**Drafting square.** Register a plastic drafting square against the narrow shoulder to divide the "giant tenon" into small tenons.

pairs of tenons. To retain your sanity, please put a big ugly scribble on the waste areas.

Now to the table saw. I've set the blade height as shown above, just a hair shy of the shoulder. I'm using my miter gauge to cut the tenons. For larger boards, a large facing attached to the miter gauge or crosscut box would be more stable and safer. I do not cut all the way to the edge of the board to avoid grain blowout. If you are doing multiple boards, just mark out one of them and set up stops to



**Tenons.** Set your saw blade height as shown, then use your miter gauge to cut the tenons.

do the rest of the boards. If you are an assassin with the dovetail saw, feel free to do all of this by hand.

At the edge of the board I will do that last cut by knifing, sawing and paring as necessary. This will keep the joint line tight, just as in cutting dovetails.

I cleared the waste between the tenons by sawing close with a bow saw then cleaning up



**Clean up.** Knife, saw and pare the outside shoulder.



**Wasted away.** This is the result after clearing the waste between the tenons by sawing close with a bow saw then cleaning up with chisels – using the shoulder line as a guide.

with chisels using the shoulder line as a guide. The waste could also be cleared by nibbling on the table saw. This is another dovetail-making skill, made easier by the square cuts and the shoulder.



**Rule for marking.** In this  $\frac{3}{4}$ " stock, I flared the mortise about  $\frac{3}{64}$ " on each side. That happens to be the width of one of my rulers, which I simply placed against the blade of my square.



### Mortises: Some Careful Layout

I've squared a line across the inside face of the mortise board, then placed the edge of the row of tenons on that line, marked the tenon width, then squared the second line across. Register the front edges of the tenon and mortise boards then mark the cross lines on the mortise board directly from the tenons. "X" the waste! Do all of this also on the reverse face, the outside of the mortise piece.

I find I usually get enough accuracy with a very fine pencil point, especially if it is sharpened on sandpaper to a chisel edge. A marking knife across the grain and an awl along the grain also work well. Take note, based on your marking-out procedure, whether you will chisel to split a penciled line or cut to one side of it.

Now mark the width of the mortise "flare" on the outside face only. In this  $\frac{3}{4}$ " stock, I flared the mortise about  $\frac{3}{64}$ " on each side. That happens to be the width of one of my rulers, which I simply placed against the blade of my square. This works out to be about a  $4^\circ$  slope for the flared part of the mortise. A bit of trial and error with a mocked-up tenon will help determine a good slope for a given wood. I suggest a conservative amount of slope to avoid split tenons. This will be plenty strong—it would be a fairly strong joint without wedging the tenons.

**Mortises.** Begin the mortises by drilling out the waste as shown at left, then chisel the edges square as shown below.



I begin cutting the mortises by drilling out the waste using a good quality lipped brad-point bit. Turn on the radio and chisel the edges square, working in from each face, guided by the marked lines. Remember that each mortise is tapered on its end-grain walls. The mortise should start to widen about  $\frac{1}{8}$ " away from the inner face of the board. This gives a "grip" around the tenon at its base, above which the tenon flares out.

Back to the tenons. The ends of the tenons get a chamfer, which will ease fitting and assembly. I used a marking gauge to scribe for the saw kerfs about  $\frac{1}{8}$ " from the edges of the tenons. I saw the kerfs by hand, stopping the cuts about  $\frac{1}{8}$ " from the base of the tenons and angling the cuts to allow the tenons to bend easier. Alter this angle depending on the stiffness of the wood you are working.

Dry fit and clean up as necessary.

### Time to Make the Wedges

I've crosscut about  $1\frac{1}{2}$ " of length from the squared end of a board the thickness of which matches the width of the tenons along the kerfs. Use a sturdy, diffuse porous wood such as the pear I'm using here. I've set the miter



**Back to the tenons.** With a marking gauge, scribe lines for the saw kerfs about  $\frac{1}{8}$ " from the edge of the tenon, and saw by hand.

gauge at about 2° – about half the angle of the mortise flare. After an initial waste cut, the workpiece is flipped over after each cut, doubling the angle, producing a 4° wedge. The saw fence and stop-block are set by trial and error to produce a wedge with a point that is equal in thickness to the saw kerfs in the tenons.

A bit of trial and error may be necessary. I change the miter gauge angle until I'm making wedges that spread the tenon enough to fill out the flare of the mortise without the wedges bottoming out in the kerf. You can use calipers to check the wedge thickness at the level it will be at the top of the finished tenon. Better yet, do a dry test fit. There should be no splitting.

The end of each wedge gets a tiny chamfer to ease its entrance into the kerf. This really helps at glue-up.

At the dry-assembly stage, there is the opportunity to plane the faces of the tenon board after pulling apart the dry assembly. As discussed near the beginning of the article, this is valuable cosmetically and also allows for the fine adjustment of a partition in a case. As an added bonus, small errors at the base of the tenons or some undercutting are hidden by the shoulder. (I never undercut my joints. And oh, yeah, my dog ate my homework.)

Get organized and stay calm, I tell myself, because it's time for the glue-up. Depending on the width and flatness of your boards, it may be necessary to use clamping cauls across the joint when assembling a case. I prefer a slow-setting glue because this is a busy glue-up. Using a small steel hammer, I tap the wedges in together as a pair to allow a symmetrical spread of the tenon and therefore a symmetrical look to the finished pair of wedges.

Finally, for all of the effort, it is so sweet to saw the tenons flush and see the joint. Also, looking at the inside of the carcass, there is a clean joint line.

True, there are a lot of steps to making this joint but it's also comforting to know that the work proceeds logically and there are some built-in allowances for error. It's something to use for your best work. Try one out for practice then give it a go in a project. In any case, enjoy, and don't worry – the stuff grows on trees. **PW**

*Rob has been a woodworker for more than 25 years; his shop is in Needfield, Mass., just outside of Boston. You can see more of Rob's work at [pwoodwork.com](http://pwoodwork.com).*

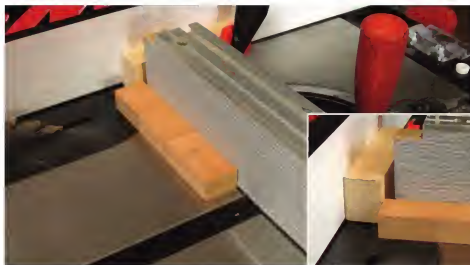

**Making wedges.** The wedge stock is flipped over after each cut. The stop-block, clamped to the saw fence, controls the wedge thickness.



**Test run.** Do a dry fit (without wedges) to ensure the pieces fit snug, and clean up your cuts as necessary.



**Don't split.** The wedges spread the tenon to fill the flare of the mortise.



**All together now.** Dry assemble the joint, and take a deep breath before glue-up.



**Last step.** Add glue and tap in the wedges. After the glue dries, saw the wedges flush.



**Voilà.** Here's the completed joint, sawn flush.

# Greene & Greene

Awakening of a style.

BY DAVID MATHIAS &  
ROBERT W. LANG

One hundred years ago, two brothers were in the midst of an amazing period of creative success. The result was a unique, enduring style that is instantly recognizable. The brothers were Charles and Henry Greene, and the style is a synthesis of Arts & Crafts with Asian influences, a casual California sensibility and obsessive attention to detail.

Few understand the work of Greene & Greene better than Jim Ipekjian. While visiting a Greene & Greene home with him, he pointed out a difference in two details at the stairs. After more than a decade in the house, the home's surprised owner had not noticed the subtle distinction. This is likely common as the Greens put considerable thought and effort into details that few would notice, or have the opportunity to see.

Greene & Greene's earliest commissions were modest but well executed homes in the style of the day. Within a decade of opening their practice, they were working on more substantial homes and began designing the interiors as well.

Drawings from 1903 depict rooms incorporating built-ins and Stickley

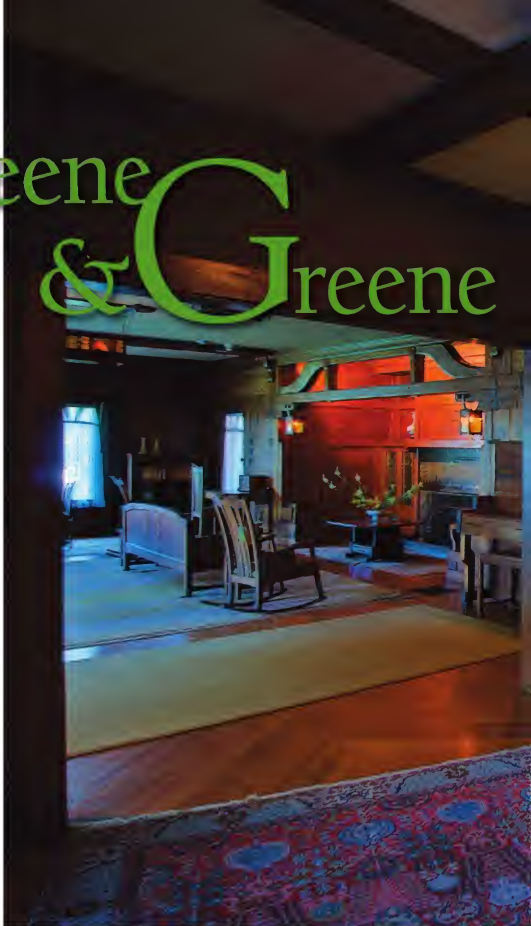

*The Greene & Greene style. Rich woods bathed in sunlight are an integral part of the style. Charles Greene considered the Robert Blacker house (right) his masterpiece. It isn't difficult to imagine why. With an interior in which every detail has been treated with care, the house is breathtaking. The best-known Greene & Greene work, the David Gamble house (above) is similarly stunning. The period details are intact, and the house transports visitors to 1908. The Freeman Ford house (far right) is less well-known, but it is a beautiful demonstration of the Greens' versatility and the Hall brothers' craftsmanship.*



pieces. By the next year they were designing complete environments down to lighting fixtures and fireplace tools. Two years later the firm was designing most of the furniture and household items for truly grand residences, now known as "Ultimate Bungalows."

The Blacker, Ford, Gamble, Pratt and Thorsen houses, built between 1907 and 1910, constitute an amazing body of work in a fully realized, mature style; the culmination of a brief yet astounding period of development.

This article is the first in a series examining the Greene & Greene style and a marvelous evolution. The focus here is a broad overview of how the style evolved. The next article will

explore details of the brothers' well-known furniture designs. Even everyday objects can be beautiful, so the third article will focus on doors as well as kitchen and bath cabinets.

### The Vocabulary of the Style

Attempting to deconstruct and explain a masterpiece is a risky business. We can describe component parts but any narrative is bound to be incomplete—genius is always more than the sum of its parts. Yet an understanding of those parts, the design vocabulary, is helpful.

Greene & Greene designs are rich with many notable elements. Among the best-known are cloudlift forms, ebony pegs and

breadboard ends. Lifts and pegs, in particular, have been the subject of countless words and rightly so. They are beautiful and essential to the look and feel of the style.

Other elements are equally important but less well-known. These include finger joints, "tsuba" shapes (a *tsuba* is a Japanese sword guard), carved details, wonderful handles and pulls, and intricate inlays.

A "typical" piece of Greene & Greene furniture, if such an item exists, is constructed of mahogany or teak with ebony accents. The shapes are organic and sensuous. The silky surfaces shimmer and beg to be touched. At their cores these designs are straightforward.

## Unifying Themes



**Unifying themes.** The Gamble house inglenook is home to fabulous architectural details. The post and beam timbers are a dominant design detail in the living room.



**Attention to detail.** The stairway in the Blacker house entry turns mundane items into beautiful design features.



**Architectural details appear in the furniture.** Lifts and carved details in the living room furniture evoke the feel of the architecture. The common vocabulary provides unity.



**Exteriors share design themes.** The scroll detail from the Blacker entry hall appears on an exterior beam.



**Room-specific detail.** The scroll is featured in the Blacker entry, but largely absent elsewhere in the house.



**Work in progress.** The second-floor stairs in Charles Greene's home were added in 1906. The house was in constant flux, growing with Charles' family.

## Evolution: Stairs



**Pinnacle of stair building.** By the time of the Gamble house, the Greens and Halls had perfected residential stairs. This is banister nirvana, just inside the front door.

## Evolution: Built-ins



**Ingenlook.** This early display cabinet forms one side of an ingenlook in the Jennie Reeve house.



**Sideboard.** This massive cabinet in the Ford house utilizes the three peg pattern.



**Elegant early cabinet.** Though simple, the Reeve house dining-room cabinet is quite attractive.



**Refining the form.** This Ford house cabinet is also simple but certainly more detailed.



**Ultimate built-in.** Once again, the Gamble house provides the culmination of the evolution. This sideboard is exquisite. The art-glass window lends a wonderful glow to the mahogany.



**All in place.** The dining-room cabinet from the Thorsen house is the epitome of the style.

Visual interest is seen in subtle ways. Light and shadow are critical and help to unify furniture designs and surrounding architecture.

In a Greene & Greene home, it is difficult to tell exactly where furniture ends and interior woodwork begins. Materials and execution are similarly beautiful; the only practical difference is that the furniture can be moved. Common elements among furniture and architectural elements enhance the effect.

Each piece of furniture was designed to occupy a place in a particular room. There were no generic forms designed to fit into many settings. This allows commonality of design within a room or entire interior. Themes continue outside where some details make another appearance, blurring the distinction between inside and outside.

Some design elements appear repeatedly in both furniture and architecture. Others are used less often. In some cases, a feature is used throughout a house. In others, it may be limited to one room. A good example is the brackets that appear on furniture in the Blacker house living room.

Brackets are used elsewhere in the house (on windows), and to a lesser extent in other houses, but the double bracket is quite limited. Similarly, a detail in the Robinson house living room is almost unknown elsewhere in the Greene canon. There, a built-in cabinet and the mantle both exhibit vertical elements with a strongly curved front surface.

This is quite a departure from the Arts & Crafts norm. Finger joints, on the other hand, are ubiquitous in furniture and trim. They vary significantly but share the same general form and are unmistakably Greene & Greene.

## The Evolution

The Greene & Greene style was not static. It grew and developed at an exhilarating rate. The earliest furniture, for the Tichenor house (1904), was not surprisingly influenced by Stickley. Charles was a regular reader of *The Craftsman* magazine and the Greenes recommended Stickley pieces for homes where they did not design furniture.

By the time of the Blacker house (1907), the Greenes had established a unique American style and some of the most exquisite furniture ever produced in this country. By the time the Thorsen furniture was completed in 1913, they had designed a mind-boggling number of fantastic pieces in a few short years. The term "evolution" seems inadequate to describe work at such a scale and pace.

So what changed? It is easy to point to the elements of the design vocabulary as the answer, but the reality is more complex. Some elements, such as lifts, were present in the earliest pieces and some later pieces are quite simple yet clearly superior to their predecessors. Intangibles play a significant role.

The rapid development of the Greenes' trademark style after 1905 was made possible by the fact that they could depend on talented craftsmen to implement their designs. In 1905, their firm began working with contractor Peter Hall and his brother, John Hall.

The first project was the Robinson house, a stunning, beautiful mansion. The first commission on such a scale, this house presaged the work the Greenes and Halls would do for the Ultimate Bungalows. It stands as a testament to what Charles could achieve with a substantial budget and skilled artisans.

Some speculate that there was a good-natured competition between the Greenes and the Halls. The Greenes would design increasingly difficult pieces and the Halls would up the ante by delivering flawless execution, as if to say, "Is that all you've got?"

In the final analysis, it's impossible to express a formula for a well-designed Greene & Greene piece. Adequate evidence for this exists in the form of poor imitations. Even many "reproductions" are lacking.

Though the style is hard to define, there are words that capture the feel. "Graceful" is the first that comes to mind. This derives from the scale and proportion of the pieces but also from the easy interplay of component parts. Nothing is forced or overdone. It is said that a good melody is inevitable. So it is with Greene & Greene furniture. What to add or remove to improve a piece? The answer is nothing. It's difficult to imagine it any other way. **PW**

*David is a woodworker in Columbus, Ohio, who spends his spare time teaching computer science at the Ohio State University. Bob is senior editor of this magazine and the author of "Shop Drawings for Greene & Greene Furniture" (Cambium Press).*

## Evolution: Furniture



**Uplifting touch.** Gently curved stretchers brace the Bolton house server.



**Exotic wood and semi-precious stones.** Inlays add elegance to Mrs. Gamble's desk.



**Stunning Sterling.** In the Gamble house guest bedroom, the inlays of silver and fruit woods.

**Repeating theme.** The tsuba shape is the dominant theme in the Gamble house dining room, excellent in design, engineering and craftsmanship.

## Online EXTRAS

For a slide show of more never-before-published photos of Greene & Greene interiors and furniture, and for a guide to other online resources, visit:

[popularwoodworking.com/aug08](http://popularwoodworking.com/aug08)





**Harmony from floor to ceiling.** No photo can do justice to the Blacker living room – it is perfect. Many consider these armchairs to be the ultimate Greene & Greene furniture design. The double brackets appear on furniture throughout the room, faithfully reproduced by Jim Ipekjian.



**Desk.** This early desk from the Tichenor house would have benefited from the skills of the Hall craftsmen.



**Enter the Halls.** This similar, massive desk from the Robinson house is superior in design and execution.

# PRODUCT INDEX

	PAGE #	CIRCLE #	WEB ADDRESS
<b>ADHESIVES</b>			
Gorilla Glue	5	116	gorillaglue.com
<b>BITS, BLADES &amp; CUTTERS</b>			
Amana Tool	15	100	amanatool.com
Forrest Mfg.	11	115	forrestblades.com
Routerbits.com	74	137	routerbits.com
<b>BOOKS &amp; VIDEOS</b>			
Foredom Electric	74	158	foredom.com
Popular Woodworking Books	37	—	popularwoodworking.com
<b>FASTENERS</b>			
Phillips Fasteners Products	2	134	lowesforpros.com
<b>FURNITURE &amp; PROJECT PARTS</b>			
Osborne Wood Products	31	131	osbornewood.com
<b>HAND TOOLS</b>			
Blue Spruce Toolworks	74	102	bluesprucetoolworks.com
Bob's Rule	19	103	bobsrule.com
Bridge City Toolworks	19	105	bridgecitytools.com
Craftsman Studio	74	108	craftsmansstudio.com
Crown Plane Co.	74	109	crownplane.com
Fine Tool Journal	74	114	finetoolj.com
Japan Woodworker	21	121	thajapanwoodworker.com
Lie-Nielsen Toolworks	21	125	lie-nielsen.com
Tools for Working Wood	19	142	toolsforworkingwood.com
<b>HARDWARE</b>			
Whitechapel Ltd.	31	145	whitechapel-ltd.com
<b>KITS &amp; PLANS</b>			
American Furniture Design	75	101	americanfurnituredsn.com
Craftsman Plans	74	—	craftsmanplans.com
Pygmy Boats	74	—	pygmyboats.com
Saturday Sawdust	75	138	saturdaysawdust.com
Texas Knifemaker	74	141	texasknife.com
U-Bild.com	75	143	u-bild.com
<b>POWER TOOL ACCESSORIES</b>			
Craftsman Gallery	19	107	thecraftsmangallery.com
FeatherBow	74	112	featherbow.com
Keller & Company	75	123	kellerdoveatl.com
Leigh Industries	21	—	leighjigs.com
<b>POWER TOOLS</b>			
Bob Marino's Festool Store	19	—	bobmarinosfestools.com
Bostitch	74	104	bostitch.com
CarveWright	74	106	carvewright.com
Fein Power Tools	7	113	fein.com
Grex USA	11	118	grexusa.com
Grizzly Industrial	C2-1, 13	119, 156	grizzly.com
JDS Company	C3	122	jdtools.com
RJR Studios	15	135	rjrstudios.com
Shopbot	11	139	shopbottools.com
Woodstock International	9	147	woodstockinternational.com
<b>SAWMILLS &amp; KILNS</b>			
EBC Industrial Products	31	111	ebacusa.com
Granberg International	75	117	granberg.com
Norwood Industries	74	128	norwoodindustries.com

	PAGE #	CIRCLE #	WEB ADDRESS
<b>SCHOOL/INSTRUCTION</b>			
Northwest Woodworking Studio	21	127	northwestwoodworking.com
Old English Academy of Woodworking	74	129	oefcc.com
Philadelphia Furniture Workshop	74	133	philadelphiafurnitureworkshop.com
<b>SHARPENING</b>			
Spyderco	15	140	spyderco.com
<b>SHOP ACCESSORIES</b>			
Oneida Air Systems	31	130	oneida-air.com
<b>TURNING SUPPLIES</b>			
Packard Woodworks	74	132	packardwoodworks.com
<b>WOOD &amp; VENEERS</b>			
Curious Woods	75	110	curiouswoods.com
M.L. Condon	75	126	—
Wall Lumber	31	144	walllumber.com
Woodfinder	74	—	woodfinder.com
Woodworker's Source	75	148	woodworkerssource.com
<b>WOODWORKING CATALOGS</b>			
Hartville Tool	31	120	hartvilletool.com
Rockler	21	136	rockler.com
Woodcraft	19, 37	146, 157	woodcraft.com

## Woodworking Magazine —The Book

Get your hands on *Woodworking Magazine* — now in book form!



We're pleased to offer the first seven issues of *Woodworking Magazine* in book form—252 pages and the only place you'll find the sold-out issues in print form.

*Woodworking Magazine*, a sister publication of *Popular Woodworking*, teaches the fundamental knowledge necessary for good craftsmanship.

In each issue, we challenge woodworker's conventional wisdom to find the techniques, materials and tools that work best.

QUANTITIES ARE LIMITED  
ORDER TODAY!

Order your copy today at  
[woodworking-magazine.com/books](http://woodworking-magazine.com/books)

**WOODWORKING**  
MAGAZINE

# The 7 Myths of Polyurethane

Off-repeated 'rules' that are, quite simply, wrong.

All levels of finishing are burdened with myths, but the types of finishes used by amateurs and sold in home centers and woodworking stores suffer the most. Myths about polyurethane are a good example of the problem.

## What is Polyurethane?

Oil-based polyurethane is simply a type of varnish. It's common alkyd varnish made with some polyurethane resin added. Alkyd is the resin used in almost all varnishes and oil-based paints. The polyurethane resin adds scratch, heat, solvent and water resistance to the alkyd varnish.

Pure polyurethanes (with no alkyd resin) are always two-part products. They cure in several ways: With the addition of moisture (an example is Gorilla Glue), with heat (many common plastics), or they are packaged as two separate components that cure after they are mixed (similar to the way two-component epoxy adhesives work).

The two-component polyurethanes are becoming more common in the furniture industry because they perform well and have a very high solids content, meaning less solvent to escape into the atmosphere.

One-component, "alkyd" polyurethane has become so dominant in the woodworking and home-consumer world that it's now becoming somewhat difficult to even find old-fashioned alkyd varnish.

Confusion has been added in the last decade or so with the introduction of water-based finishes, some of which combine polyurethane with acrylic resins. These finishes are sometimes labeled "polyurethane," with no obvious reference to their being an entirely different class of finish, one that performs less well than oil-based polyurethane and has very different application characteristics.



**No advantage.** It's not necessary to brush across the grain, as I'm demonstrating here, to work the finish into the wood. The finish penetrates perfectly well by capillary action no matter how it is applied.

This isn't to say you shouldn't use water-based polyurethane. Just be aware that it is an entirely different finish – a water-based finish. This article deals solely with oil-based polyurethane.

## The Myths

Myths are much more prevalent in finishing than in woodworking because finishes are chemistry, and you can't always "see" differences in chemistry. For example, polyurethane and lacquer look the same, both in a can and on the wood, even though they have very different characteristics.

In contrast, woodworking is physics. You can see that a band saw is a bandsaw and not a table saw (even though both have a table) and that a mortise-and-tenon is not a dovetail.

So authors and manufacturers have much more opportunity to provide inaccurate information, intentionally or not, about finishes than about woodworking tools and procedures. And consumers are more vulnerable to misinformation – that is, "myths" – about finishing than about woodworking.

Once a myth gets into print, it's common for it to be repeated endlessly until it becomes "fact," simply because everyone says

it. Here are some of the most common myths concerning polyurethane (and varnishes in general).

■ **MYTH #1: Brush across the grain first to work the finish into the wood.** All finishes soak perfectly adequately into the wood no matter how they are applied. They do this by capillary action, the same physical phenomenon that allows water and nutrients to rise from the ground to the top of a tree.

If it were necessary to brush across the grain first, or diagonal to it (as I've also seen advocated) to get the finish to penetrate into the wood, how would a sprayed finish penetrate?

The only benefit gained by brushing first across the grain and then with the grain (to line up the brush strokes with the grain) is to make the thickness of the application more even. But I never have a problem with some areas being noticeably thicker than others anyway.

More important, the longer polyurethane is brushed the more thinner evaporates, and this causes the finish to thicken and brush marks to be more pronounced.

■ **MYTH #2: Thin the first coat 50 percent to get a good bond.** This is an old myth that probably got its start because of poor understanding of the role of primers used under paint, and sanding sealers sometimes used under varnish and lacquer.

Primers do create a better bond for paint because they contain a higher ratio of binder



***Bubbles.** If you shake a finish vigorously, as I did this jar containing polyurethane (left), thousands of tiny bubbles appear. These can be transferred to the wood by a brush. But bubbles appear on the wood even when you don't shake the finish because of the turbulence caused by the brush movement, as I'm demonstrating here with polyurethane I didn't shake (right). So it's more important to know how to deal with the inevitable bubbles than to follow instructions not to shake.*

(finish) to pigment. But finishes are all binder, so they bond perfectly well without a separate product.

Sanding sealers contain a soap-like lubricant that makes the sanding of the first coat easier and faster, so they are especially useful in production situations. But they weaken the bond of the finish, so unless you're doing production work, you're better off not using a sanding sealer.

Polyurethane bonds especially poorly to sanding sealers, so most manufacturers of polyurethane discourage their use. Furthermore, polyurethane sands easily, so there isn't any need for a sanding sealer.

Nevertheless, the existence of primers and sanding sealers (and the recent addition of "SealCoat," a dewaxed shellac from Zinsser, marketed for use as a "sealer" under polyurethane) have created a belief among some that something has to be put under the polyurethane to make it bond better.

And those who believe this have come up with the idea of thinning the finish.

In fact, the only benefit gained by thinning is faster drying. The thinner the layer of any finish, the faster it dries, and the sooner it can be sanded and the next coat applied. So there is a benefit, but it's not improved bonding.

■ **MYTH #3: Never shake the can or you'll introduce bubbles.** A corollary is: Never wipe the bristles over the rim of the can because this will also introduce bubbles into the finish.

This is a very old myth that is more "misleading" than "myth" because it's true but it doesn't matter. I don't know when the myth started, but it is so well established that it's

even highlighted in bold letters on the cans of common brands such as Minwax and Olympic polyurethane.

Sure, if you shake the can, bubbles appear in the finish. And if you then brush the finish, bubbles appear in it. But they appear in the brushed finish even if you don't shake the can. This should be the clue that shaking isn't the critical factor — brushing is.

If the great majority of bubbles are the result of the turbulence caused by the rapid movement of the brush, the way to avoid bubbles could be to brush very slowly to reduce the turbulence.

The published instruction from one author who suggests doing this is to brush one foot every eight seconds and not brush back over. Try it. It's almost impossible to brush this slowly. And not brushing back over to stretch out the finish and thin it on the wood — and also line up brush strokes — leads inevitably to runs on vertical surfaces and build-up on horizontal surfaces wherever you set down a finish-loaded brush.

So you're going to get bubbles if you brush, whether or not you shake the can. The trick is to know how to keep the bubbles from drying in the finish.

Usually, bubbles pop out on their own. But on hot days when the skinning-over occurs faster and traps the bubbles, you may need to help the popping along by "tipping-off" using your brush. Brush lightly back over the finish right after application. (You should do this anyway to line up the brush strokes with the grain.) Most of the bubbles will disappear.

If the tipping-off doesn't work well enough, add 5 or 10 percent mineral spirits to keep



***Sanding.** Not only does polyurethane not need thinning or a special product to create a better bond to the wood, but it also sands easily on its own without clogging sandpaper.*

the finish "open" longer and give the bubbles more time to pop out.

Some brands of polyurethane, such as Minwax, bubble noticeably more than others, but this is rarely a problem because the bubbles tend to pop out quickly.

There are two ways to deal with bubbles that won't pop out. The first is to wipe off the bubbled coat of finish using a rag dampened with mineral spirits, naphtha or turpentine. You can do this for 15 to 30 minutes after application without a problem. You won't damage the coat underneath, and you don't have to get all the polyurethane removed. Simply wipe until what is left is smooth and bubble-free.

The second method is to let the bubbled finish dry and sand it level before applying another coat. Thin this coat enough with mineral spirits so the bubbles have time to pop out.

The disservice caused by attributing bubbles to shaking rather than to brushing is that users become frustrated and lose confidence when they follow directions and still don't avoid the problem.

■ **MYTH #4: Thinning with naphtha makes polyurethane dry faster.** Naphtha evaporates much faster than mineral spirits or turpentine. So the logic behind this myth, which is fairly new, is that the finish will dry faster if the thinner evaporates faster.

But, like all varnishes, polyurethane dries in two steps. The first is evaporation of

the thinner. The second (and much longer) step is the curing, which is the crosslinking brought about by the introduction of oxygen from the air.

When you apply polyurethane, you notice that it stays wet on the surface for a short time as the thinner evaporates. Then the finish goes into a tacky or sticky stage for an hour or longer. This is the length of time it takes for the oxygen-induced crosslinking to occur. Adding a faster-evaporating thinner doesn't speed this crosslinking.

In fact, adding naphtha probably has no noticeable effect on the drying of the finish beyond the impact of thinning described at the end of the second myth.

■ **MYTH #5: Thinning with Penetrol reduces brush marks.** Painters have added Penetrol, a widely available additive, to oil paint for decades to reduce drag and brush marking, especially when painting in hot or cold weather, or in sunlight. But until recently I had never seen Penetrol recommended for use in polyurethane, which is usually applied indoors in more ambient working conditions and brushes easily without drag.

Penetrol is a slow-drying oil product that lengthens the tacky stage of polyurethane and oil paint. This creates more time for dust to

settle and stick to the surface. Painters don't mind because dust isn't a big problem for them, but it is for furniture finishers.

Most woodworkers want their polyurethane to reach a dust-free stage faster, not slower, as evidenced by myth #4. What little benefit might be gained in reducing brush marking is more than cancelled out by increased dust nibs. (If you want to reduce dust nibs, thin the last coat of polyurethane by 25 to 50 percent so it dries faster.)

Additionally, because Penetrol is an oil, it can't help but weaken the durability of polyurethane – though not enough to cause a problem in most situations, so far as I can tell. (See the next myth for the way to eliminate brush marks.)

■ **MYTH #6: Slant the panel to reduce brush marks.** I read this myth for the first time only recently. The idea is to get brush marks to flow together by tilting flat panels such as tabletops 5° or 10° off the horizontal.

Not only is this a tricky procedure that will lead to sagging if you aren't careful to keep the finish thin on the surface (similar to the difficulty brushing vertical surfaces), but the procedure doesn't make any sense. It's not gravity causing one brush-mark ridge to sag into another that reduces brush marking.



**Sticky stage.** Once the bubbles have popped out, you want the polyurethane to dry as fast as possible to get beyond the sticky stage (demonstrated here by a fingerprint in the finish) so dust nibs are kept to a minimum. Adding faster-evaporating naphtha to the finish doesn't speed the drying of this stage beyond what is accomplished simply by the thinning. You could just as well use mineral spirits.



**Penetrol.** Adding Penetrol (a widely available additive for oil paint) to polyurethane slows its drying so dust has more time to settle and stick to the finish. Any possible gain in reduced brush marking is more than cancelled out by the added dust nibs.



**Brush marks.** The way to apply a brush-mark-free finish using polyurethane is to first sand out the brush marks on the next-to-last coat using a flat backing block and a mineral oil, mineral spirits or water lubricant. Then thin the last coat about 25 percent with mineral spirits so it levels well.

It's gravity evening out the difference between the ridges and the troughs that eliminates brush marking.

Some brands of polyurethane level naturally better than others because of their formulation. But all polyurethanes can be made to level perfectly by adding mineral spirits. So the way to get a brush-mark-free finish is to sand the next-to-last coat level, then thin the last coat enough so it levels well.

The amount of thinner necessary varies with brands. My suggestion is to begin with about 25 percent mineral spirits and adjust from there.

■ **MYTH #7: Scuff sand between coats to get a good bond.** The purpose of this instruction is to create scratches in the surface so the next coat of finish can establish a "mechanical" bond. The finish "keys" or "locks" into the sanding scratches.

This myth is somewhat complicated. The first clue that sanding between coats isn't so critical is that you rarely create scratches everywhere anyway. There are almost always gaps in your sanding – for example, in the pores, in recesses and often just because you aren't being thorough enough.

And yet, the next coat usually bonds well anyway, especially if not a lot of time has gone by between coats. How often have you seen coats of polyurethane separating?

Here's the way to approach sanding between coats: Do it anyway. Polyurethane dries slowly, so there are always dust nibs that should be sanded out before the next coat is applied.



**Slant panel?** Slanting a panel 5° or 10° is not the way to reduce brush marking, but this has actually been suggested recently. You would have thought furniture finishers working during the last several hundred years would have figured this out if it were true.

For two reasons, pay more attention to doing a thorough sanding if you are using a gloss finish than if you are using one with flattening agents included (semi-gloss or satin). First, even tiny flaws show in gloss finishes, while they are often disguised in semi-gloss and satin. Second, finishes don't "wet" and bond as well to gloss surfaces as they do to dull surfaces. (The dullness in semi-gloss and satin finishes is caused by a microscopically rough surface created by the flattening agent.)

Use a sandpaper grit that removes the flaws efficiently without creating deeper scratches than necessary. I almost always sand with #320 or #400 grit, regular or "P" grade. There have to be big flaws in the surface to require sanding with coarser grits.

Never back the sandpaper with a flat block when sanding between coats to remove dust nibs, though it would be all right to do this if the surface is truly flat. The biggest problem using a flat block is that you are more likely to clog the sandpaper and the clogs, or "corns," will put deeper scratches into the finish that might telegraph through the next coat.

You can also abrade with steel wool or a synthetic abrasive pad, but neither cuts and levels as well as sandpaper.

## Conclusion

Brushing polyurethane is not complicated, but somehow authors and manufacturers have succeeded in making it seem so. They have done this by introducing myths into

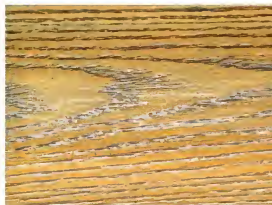

**Scuffing.** The main reason to sand polyurethane between coats is to level dust nibs and other flaws, not to create a better bond. This is demonstrated here by the gloss remaining in the pores after sanding the surface. The next coat of finish still bonds in the pores even though the finish there is rarely scuffed.

their instructions. Some of the myths make no sense but do no harm. Others purport to solve a problem, and when following them doesn't help, frustration sets in.

It's unfortunate, but once a myth gets into print, nothing, not even an article such as this, seems to have any impact slowing its spread.

Probably the opposite, in fact. Conspiracy theorists know that merely repeating an "untruth" in order to debunk it tends more to solidify it in the minds of believers. **PW**

*Bob is the author of "Understanding Wood Finishing" and a contributing editor to this magazine.*

BY DAVID MATHIAS

# Memories and Milestones

Connecting an Arts & Crafts icon with the men who made it 100 years ago.

On a Sunday afternoon not too long ago, I found myself sitting in a home in Southern California looking at the family heirlooms of a friend. It was great fun to watch him display these items with obvious pride in the accomplishments of his family. There were the typical objects: old photographs, business papers and personal items.

There were also drawings of historically significant furniture and tools used by highly skilled craftsmen. My friend's name is Gary Hall. Peter Hall was his grandfather and John Hall his great uncle. Together with Charles and Henry Greene, the Halls helped create what many hold to be the ultimate expressions of the Arts & Crafts movement in America. The Hall's contributions to the work of the Greenses are well documented, their place in history well deserved. Most fans of Greene & Greene know something of Peter and John Hall, the craftsmen. On that afternoon, I got to know a little about Peter and John Hall, the men.

In 1905 Peter formed his contracting company and began his relationship with Greene & Greene. John joined him soon thereafter. The relationship between Peter and John Hall is often compared to that between Charles and Henry Greene. Peter and Henry were more pragmatic and business-minded, John and Charles more artistically inclined.

Except for the Thorsen house pieces, furniture for the Greenses was made in Peter Hall's workshop. When the furniture business declined, the shop-made wooden boxes for California fruit and candy companies. In 1921, the shop was destroyed by fire and never rebuilt.

Peter Hall was involved for much of his adult life in gold mining. Between 1898 and



The Gamble House Centennial

1908-2008  
Greene & Greene



1904, he spent summers mining in Alaska. After he began working with the Greenses, Peter invested in mining companies. Most of his investments were lost later in his life, but the family still holds mineral rights to a parcel of land in California.

For a while, Gary and I paged through a business journal kept by Peter's secretary. In the book were accounts receivable for contracting work well after the association with the Greenses had ended. In the days before calculators, contractors figured costs using printed tables. Gary has a book of tables that his grandfather used to calculate his costs for lumber (you don't want to know the board foot prices for lumber at that time).

This year marks the centennial of the best-known collaboration between the Greenses and

Halls—the David and Mary Gamble house. The Halls built the Gamble house in only 10 months. Look again at the photos from the Gamble house that appear in this issue (page 66) then consider the previous sentence. Ten months. How did they do it?

The centerpiece of the centennial year is "A New and Native Beauty: The Art and Craft of Greene & Greene," an exhibition of the brothers' designs. The initial installation, at the Huntington Library's Art Collections and Botanical Gardens, will run from Oct. 18, 2008 until Jan. 4, 2009. It will then travel to the Renwick Gallery of the Smithsonian (approximately March to June 2009) and the Museum of Fine Arts in Boston (approximately August to October 2009).

The exhibition is a must for any Greene & Greene fan and an unparalleled introduction for those just discovering the genre. It will include 160 examples of their work including furniture, art glass, metal work, textiles, drawings and archival photographs. Some of the pieces have never before been available to the public. Also on display will be hand tools that belonged to John and Peter Hall—an added bonus for us woodworkers.

Centennials don't come along every day. And those celebrating true masterpieces are quite rare. If you choose not to go to the exhibition though, don't get too discouraged. I'm sure the celebration for the 200th anniversary will be just as good. **PW**

*The Gamble house is the only Greene & Greene home regularly open to the public. More information about tours is available online at [gamblehouse.org](http://gamblehouse.org), or by phoning 626-793-3334. The poster pictured above is available as a limited-edition block print, directly from the Gamble House bookstore. Information about the Huntington exhibition is available online at [huntington.org](http://huntington.org), or by calling 626-210-0100.*